



www.monoequip.com

OVEN SERIAL NO. _____
OVEN CODE 149 150 153 156 158 159

CONDENSER SERIAL No. _____ (IF FITTED)
In the event of an enquiry please quote these numbers.



Bx OVEN

SET UP AND OPERATION OF OVEN
AND CONDENSER UNIT (IF FITTED)



COLOUR



DECLARATION OF CONFORMITY

We hereby declare that this machine complies with the essential health and safety requirements of :-

- The Machinery Directive 2006 / 42 / EC
- The Low voltage Directive 2014 / 35/ EC
- The requirements of the Electromagnetic Compatibility Directive 2004 / 108EC, 91 / 263 / EEC, 92 / 31 / EEC
Incorporating standards
EN55014-1:2006+A1:2009+A2:2011
EN55014-2:1997+A1:2001+A2:2008
- The General Safety of Machinery and food processing Standards applicable
- Materials and Articles intended to come into contact with food
Regulation (EC) No. 1935 / 2004

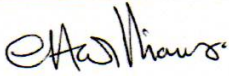
Signed	
G.A.Williams – Quality Manager	

Date	
-------------	--

Machine FG Code.		Machine Serial No.	
-----------------------------	--	-------------------------------	--

A technical construction file for this machine is retained at the following address:

MONO EQUIPMENT
Queensway,
Swansea West Industrial Park,
Swansea
SA5 4EB
UK

MONO EQUIPMENT is a business name of **AFE GROUP Ltd**
Registered in England No.3872673 VAT registration No.923428136

Registered office: Unit 9, Bryggen Road,
North Lynn Industrial Estate,
Kings Lynn,
Norfolk,
PE30 2HZ

ATTENTION

IF OVEN FAILS TO HEAT UP, WHEN FIRST CONNECTED TO A POWER SUPPLY OR DURING USE AT ANYTIME, PRESS RESET BUTTON(S) LOCATED THROUGH THE REAR BACK PANEL. (DO NOT REMOVE BACK PANEL)

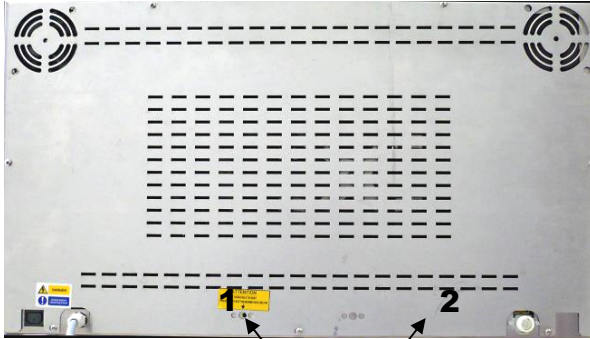

**4 TRAY OVEN
RESET HOLE LOCATION**

*HOLE CAN BE AT POSITION 1 OR
POSITION 2 DEPENDING ON OVEN*

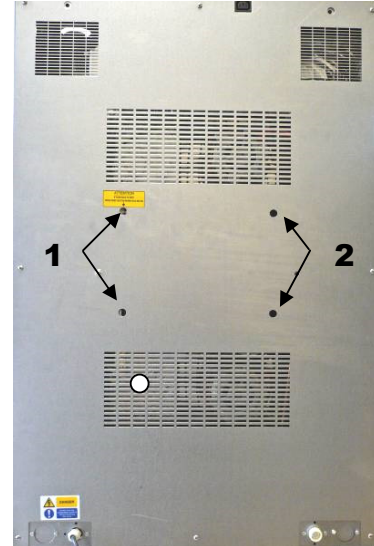

**10 TRAY OVEN
RESET HOLE LOCATION**

*HOLES CAN BE AT
POSITION 1 OR POSITION 2
DEPENDING ON OVEN*

REAR VIEW OF OVENS

IF THIS FAILS TO CORRECT THE SITUATION, PLEASE CONTACT YOUR SUPPLIER

SAFETY SYMBOLS

The following safety symbols are used throughout this product documentation. Before using your new equipment, read the instruction manual carefully and pay special attention to information marked with the following symbols.



WARNING

Indicates a hazardous situation which, if not avoided, will result in death or serious injury.



WARNING

Indicates a hazardous situation which, if not avoided, will result in electric shock.



CAUTION

Indicates a hazardous situation which, if not avoided, will result in minor or moderate injury.

ELECTRICAL SAFETY AND ADVICE REGARDING SUPPLEMENTARY ELECTRICAL PROTECTION:

Commercial bakeries, kitchens and food service areas are environments where electrical appliances may be located close to liquids, or operate in and around damp conditions, or where restricted movement for installation and service is evident.

The installation and periodic inspection of the appliance should only be undertaken by a qualified, skilled and competent electrician, and connected to the correct supply suitable for the load as stipulated by the appliance data label.

The electrical installation and connections should meet the necessary requirements of the local electrical wiring regulations and any electrical safety guidelines.

We Recommend:

- Supplementary electrical protection with the use of a residual current device (RCD)
- Fixed wiring appliances incorporate a locally situated switch disconnecter to connect to, which is easily accessible for switching off and safe isolation purposes. The switch disconnecter must meet the specification requirements of IEC 60947.

Your attention is drawn to:

BS 7671:2018 – Guidance Note 8 – 8.13 : Other locations of increased risk

It is recognised that there may be locations of increased risk of electrical shock other than those specifically addressed in Part 7 of BS 7671. Examples of such locations could include laundries where there are washing and drying machines in close proximity, and water is present, and commercial kitchens with stainless steel units, where once again, water is present. Where, because of the perception of additional risks being likely, the installation designer decides that an installation or location warrants further protective measures, the options available includes:

- Automatic Disconnection of Supply (ADS) by means of a residual current device having a residual operating current not exceeding 30 mA;
- Supplementary protective equipotential bonding; and
- Reduction of maximum fault clearance time.

The provision of RCDs and supplementary bonding must be specified by the host organisation's appointed installation designer or electrical contractor and installed by a suitably qualified and competent electrician so as to comply with Regulations 419.2 and 544.2.



The supply to this machine must be protected by a **30mA RCD**

CONTENTS		PAGE
PART 1.0	Introduction	6
PART 2.0	Specifications	7
PART 3.0	Safety	8
PART 4.0	Installation	9
PART 5.0	Isolation	10
PART 6.0	Daily / Weekly Cleaning	11
PART 7.0	Ideal Operating Conditions	13
PART 8.0	<u>COLOUR Operation</u>	14
PART 9.0	Programming	19
	Creating and changing program values	
PART 10.0	Upload / Download	21
PART 11.0	Maintenance	26
PART 12.0	Bulb Replacement	26
PART 13.0	Steam System Maintenance	26
	CONDENSER INFORMATION (IF FITTED)	27
	<i>SERVICE / SPARES</i> Contact Information	39

1.0 INTRODUCTION

- A combination of clean industrial design and the latest technology, the **MONO BX oven range** is designed specifically to take the baking Industry's standard trays.
- The ovens in the range are of **stainless steel construction** and some have removable tray racks to aid cleaning.
- The smaller ovens are designed to be **stackable** without separate support, so your business can grow without taking up more ground space.
- The high-speed fans, elements and steam systems give **efficient air circulation** to produce a professional bake across a range of products.
- The doors are **double glazed** to increase the efficiency of the ovens well-insulated baking chamber
- Ovens are supplied with the **LCD (colour)** display for the user-friendly control panels.



2-TRAY Bx OVEN



4-TRAY Bx OVEN



- The 10-tray Bx is supplied with a 10-tray capacity stainless steel base with locking castors.

10-TRAY Bx OVEN



- The optional condenser unit can be fitted to any Bx oven or stacked Bx ovens as required.
With thermostatic control it can be adjusted to operate in most ambient temperatures.

2.0 SPECIFICATIONS



The supply to this machine must be protected by a **30mA RCD**

Technical Specifications

2 Tray 4/5 Tray 10 Tray

	600 x 400	18" x 26"	18" x 30"	400 x 600	600 x 400	400 x 800	18" x 26"	18" x 30"	400 x 600	400 x 800
Tray size (mm unless otherwise stated)	600 x 400	18" x 26"	18" x 30"	400 x 600	600 x 400	400 x 800	18" x 26"	18" x 30"	400 x 600	400 x 800
No of trays	2	4	4	4	4	4	10	10	10	10
Distance between trays (mm)	90	93	93	93	84	93	100	100	100	100
No of trays (option)		5	5	5	5	5				
Distance between trays (option, mm)		74	77	69	62	70				
Height (mm)	420	525	525	525	570	525	1,170	1,170	1,170	1,170
Height of oven on base (mm)							1,870	1,870	1,870	1,870
Width (mm)	1,000	840	840	780	1,000	780	840	840	780	780
Depth, door closed incl handle (mm) *5	732	1,164	1,269	1,103	890	1,303	1,209	1,309	1,109	1,309
Depth, door fully open (mm)*5	1,062	1,729	1,828	1,610	1,610	1,810	1,770	1,870	1,609	1,809
Weight (kg) approx.	66	145	165	115	110	160	192	290	250	262
Total power required (kW)	3	7.5	8.5	7.5	7.5	7.5	17	17	15	17
Water Supply	2	2	2	2	2	2	2	2	2	2
Modularity	2	2	2	2	2	2	2	2	2	2
Landscape tray orientation										
Portrait tray orientation										
Eco-Touch controller										
Classic Controller										
Right hand hinged										
Left hand hinged										
Bottom door hinged										
Power - 1 phase electrics	1	3	3	3	3	3	5	5	5	5
Power - 3 phase electrics		4	4	4	4	4	5	5	5	5
Steam facility										
Internal Light										
Stackable										
Optional Extras:										
Calcium Treatment Unit										
Water Condenser										
Valance										
300mm high base										
595mm high base										
745mm base unit										
920mm high base										
Ovens Suitable For:										
UK										
Europe										
Commonwealth										
USA & Canada										
ROW										

Available **Optional Extra**

- ¹ 50Hz; total load 2.99kW. Plug top fused at 13 Amps
- ² Oven is supplied with a 1 metre long flexible hose with 3/4" B.S.P. female connectors on both ends. Water pressure required is **2 bar - 4 bar** (standard domestic water pressure is within these parameters). Customers are strongly advised to fit a water conditioning unit to the supply for this equipment. This unit should remove and not suspend water hardness. No drain is required for this oven. See Optional Extras for water conditioning unit.
- ³ 50Hz; fused at 40 Amps. Single phase ovens will be supplied with LEGRAND model 587-00 plug fitted to 2.5 metres of cable. Customers should ensure that a LEGRAND model 587-40 socket (or equivalent), and isolator is fitted at the position of installation.
- ⁴ 50 Hz, fused at 15 Amps per phase. Three phase ovens are supplied with a single LEGRAND model 574-29 plug fitted to 2.5 metres of cable. Customers should ensure that a LEGRAND model 0553-53 socket (or equivalent), and isolator (or model 0592-11 'dead fronted') is fitted at the position of installation.
- ⁵ 3 phase and neutral + earth; fused at 32 Amps; 415v, 50 Hz. Customers should ensure that a LEGRAND model 0553-53 socket (or equivalent), and isolator (or model 0592-11 'dead fronted') is fitted at the position of installation.

*5 excluding services
 Please contact MONO Equipment for USA electrical details.
 Specifications correct at time of publication. MONO Equipment reserves the right to amend the specification without prior notice.

3.0 SAFETY

***In the interest of safety and efficient operation of the oven, it is essential that this manual should be made available to the operator before work is commenced.
The following points should be observed and followed at all times.***

1. The oven is designed for baking of bread, confectionery and savoury products only. DO NOT use it for any other items without consulting with **MONO**.



2. The oven must be allowed to cool before any form of cleaning is started.



3. All repairs and maintenance of electrical units must be carried out by authorised electricians; even then, electrical access panels must not be opened unless the mains supply to the oven is isolated.

4. All connections to the oven must be made in accordance with the statutory requirements of the country of installation.



5. While the oven is in operation (and for some time after use), **it is inadvisable to touch the oven window or the surrounds because of conducted heat.**

6. The oven must be operated as described in this manual.

7. Only **MONO** spare parts should be used on this oven.

8. The construction of the oven must not be changed.

9. The owner of the oven is legally obliged to instruct staff of these safety points and of the safe operation of the oven. **These instructions should not be removed from the working area.**

10. To prevent door glass from shattering -
DO NOT CLEAN OVEN GLASS WHEN HOT.

11. Customers operating a BX oven in a hard water area must ensure that an efficient water-softening device protects the water supply to the equipment.



12. Oven gloves should be worn when moving products in or out of the oven.

4.0 INSTALLATION

The supply to this machine must be protected by a **30mA RCD**



1. The oven should be connected to a wall isolator.

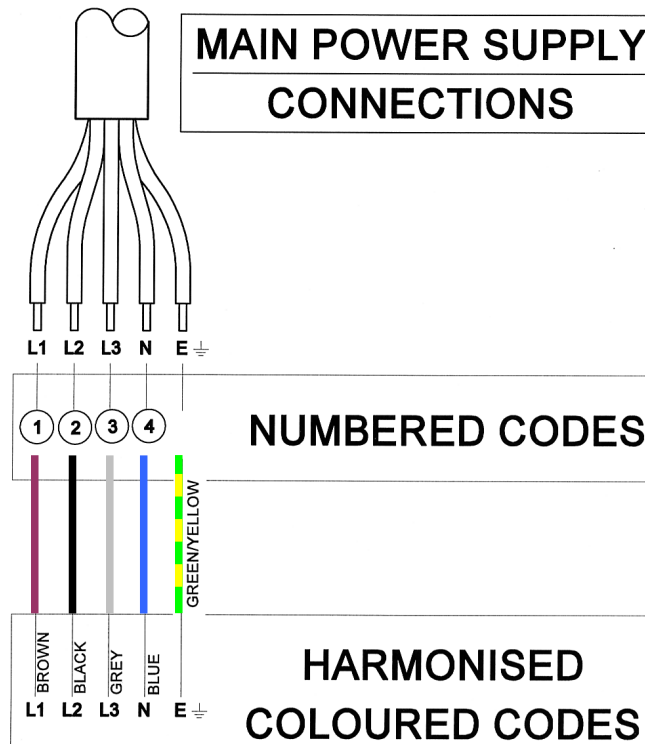

2. It is the customers' sole responsibility to arrange adequate ventilation and it should be sufficient to ensure water does not condense on or around the oven. A 50mm gap is required at the sides and rear of this oven. Chimneys and evacuation ducts, fitted above mono ovens should be insulated.
3. If an oven with steam has been chosen, connect to a suitable water supply making sure that the pipes are flushed out to remove all foreign bodies i.e. flux or solder. Customers in hard water areas must ensure that an efficient water treatment device protects the supply to the oven. It is the customers' responsibility to install and maintain an adequate water supply to the oven, which should comply with local water regulations.
4. In the interests of hygiene, we strongly recommend that before using the oven for the first time you wipe the inside of the oven and all accessories thoroughly with a clean cloth soaked in warm soapy water. Although the utmost care is taken during assembly and pre-delivery inspection, there is always a possibility of residue contaminating the first bake if this is not done.

5. Ensure that the locking castors on the base unit (if supplied) are locked into position.

6. **AMBIENT WORKING TEMPERATURES.**

Ambient working temperatures for electric/electronic components such as solenoid switches, circuit breakers, motors etc should be **no more than 40°C (115° f)**

Manufacturers of these and other electrical components advise that any ambient temperature above 40°C affects the functionality of the components and any related guarantees become void. For example, above this temperature motors are not satisfactorily cooled, contactor efficiency is seriously impaired and electronic components shut down. It is the customers' sole responsibility to arrange for adequate ventilation. Any component malfunctioning during the guarantee period that is found to have been subject to excessive humidity or ambient working temperature above 40°C (115°F) will not be covered by the component manufacturers guarantee or MONO's product warranty.

5.0 ISOLATION

ELECTRICITY SUPPLY

To stop the oven in an emergency, switch off electricity at the wall isolator.

WATER SUPPLY

For stacked ovens, the water supply can be shut off by closing the shut-off valves (See diagram)

For non-stacked ovens the water supply should be shut off at the nearest shut-off point

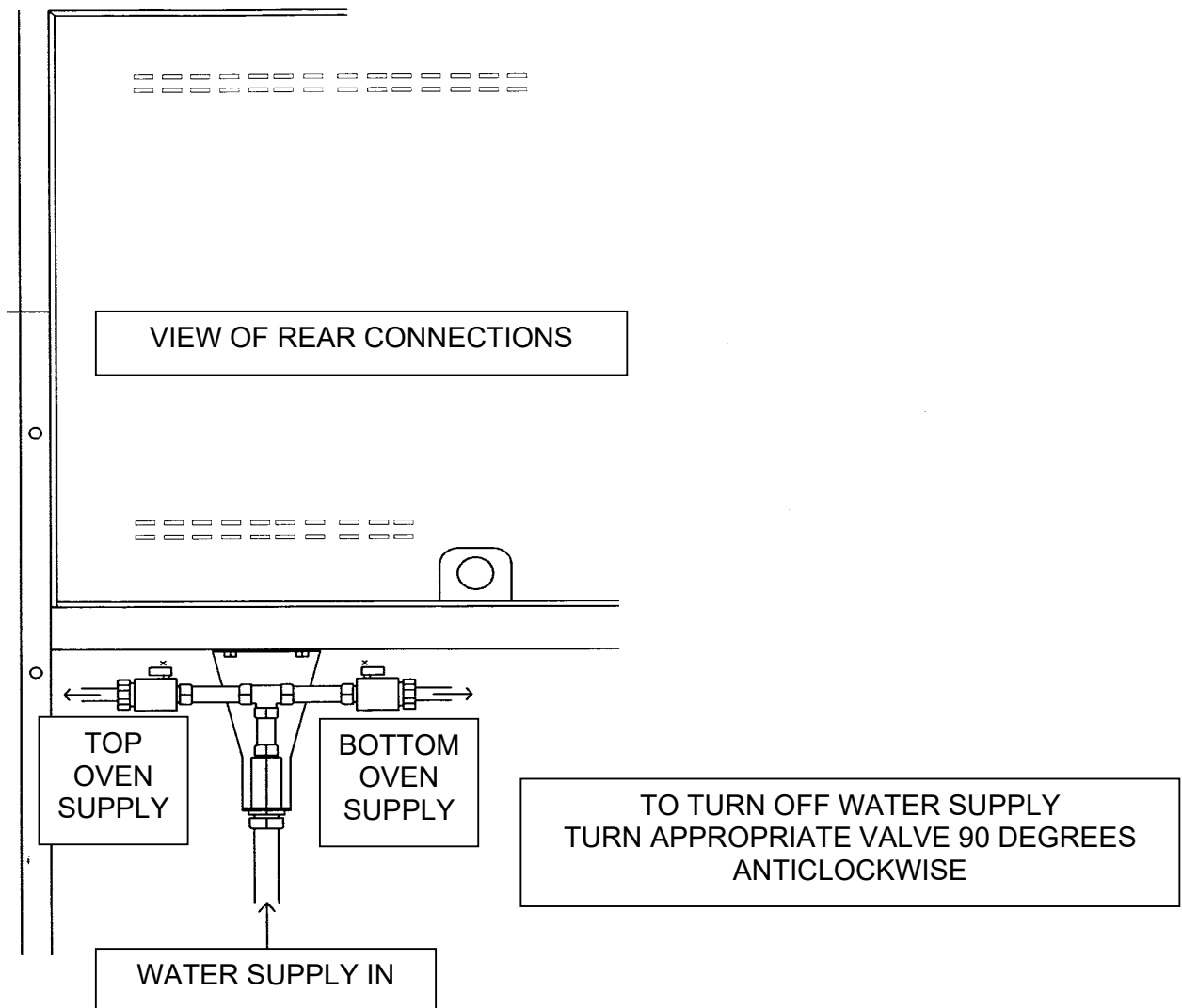

6.0 CLEANING INSTRUCTIONS

DAILY



NOTE: BEFORE CLEANING ISOLATE OVEN FROM MAINS SUPPLY AND ALLOW TO COOL.

- The equipment is to be cleaned daily using approved chloride-free cleaning fluid
- Sweep any debris (after it has been allowed to cool) onto oven removable trays and remove for cleaning.
- Brush down and wipe oven front, back and sides.
- Wipe clean with a damp cloth that has been soaked in a solution of mild detergent and hot water, paying particular attention around control switches.

IMPORTANT:

TAKE CARE WATER DOES NOT ENTER CONTROL PANEL OR REAR ACCESS PANEL.



DO NOT REMOVE THE REAR PANELLING INSIDE THE OVEN.
THIS ALLOWS ACCESS TO THE FAN ASSEMBLY WHICH IS NOT SAFETY INTERLOCKED AND COULD CAUSE INJURY

WEEKLY



NOTE: BEFORE CLEANING ISOLATE OVEN FROM MAINS SUPPLY AND ALLOW TO COOL.

Complete daily check then

- Clean any burnt-on debris by careful use of a proprietary oven cleaner, carefully following the manufacturer's instructions. Do not allow the oven cleaner to get onto control panel.
- Scrub cabinet wheels (if fitted), with a mild detergent and hot water using nylon cleaning brush.

Ovens using 60cm x 40cm trays (FG156 2 tray / FG158 4 tray)

Open oven door and remove internal racking from sides of oven.
(*lift and unlatch racking*).

This allows access to hidden areas in the oven, which can be wiped with a damp cloth.

Wipe down, and clean racking with damp cloth and replace.

4 tray ovens

The inner door glass is hinged to enable cleaning of internal surfaces.

To open, remove the two screws shown in the sketch below.

The internal surfaces of the door glass can then be cleaned using a suitable glass cleaner.

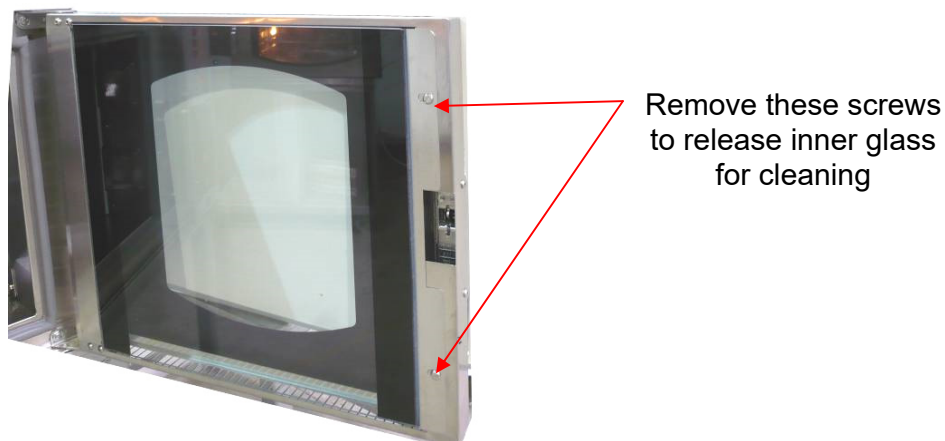

7.0 IDEAL OPERATING CONDITIONS ---

- Room should be allowed for the door to open fully to allow easy loading and unloading of product without people coming in contact with hot surfaces.
- Racks should be available to allow cooked products to cool safely.
- Oven gloves should be available at all times.
- It is the customers' sole responsibility to arrange adequate ventilation and it should be sufficient to ensure water does not condense on or around the oven. A 50mm gap is required at the sides and rear of this oven.
- Chimneys and evacuation ducts, fitted above mono ovens should be insulated

AMBIENT WORKING TEMPERATURES.

Ambient working temperatures for electric/electronic components such as solenoid switches, circuit breakers, motors etc should be **no more than 40°C (115° f)**

Manufacturers of these and other electrical components advise that any ambient temperature above 40°C affects the functionality of the components and any related guarantees become void. For example, above this temperature motors are not satisfactorily cooled, contactor efficiency is seriously impaired and electronic components shut down. It is the customers' sole responsibility to arrange for adequate ventilation. Any component malfunctioning during the guarantee period that is found to have been subject to excessive humidity or ambient working temperature above 40°C (115°F) will not be covered by the component manufacturers guarantee or MONO's product warranty.

Bx COLOUR

Operating Instructions

8.0 BXC OPERATING INSTRUCTIONS

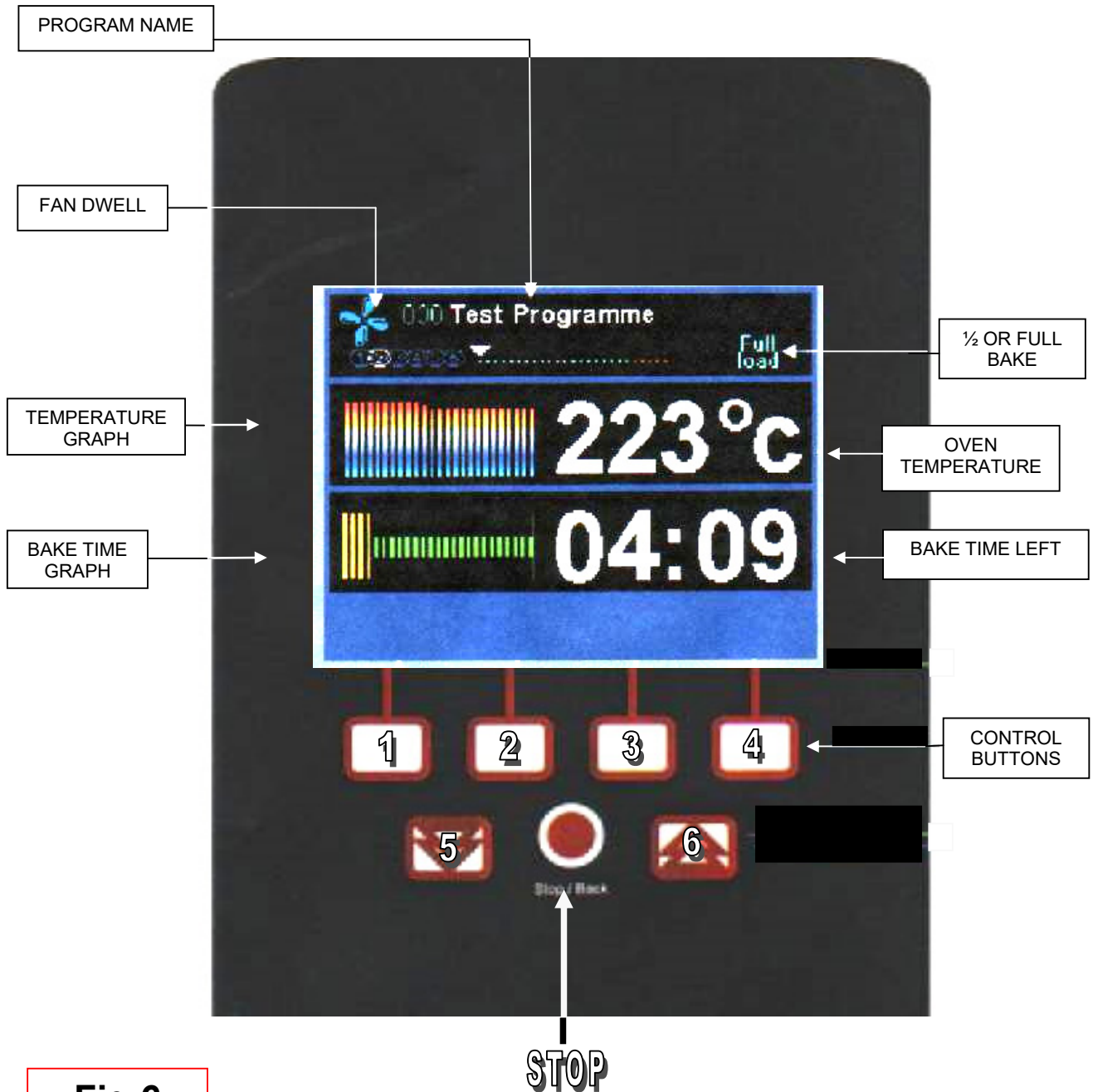

Fig 6

Control Panel – BX COLOUR oven (TO BE USED IN CONJUNCTION WITH SECTIONS 8.0, 9.0 AND 10.0)

1. Connect water ensuring there are no leaks.
2. Connect power to a suitable outlet.
3. Turn oven on by pressing green button, and the following screen will appear:

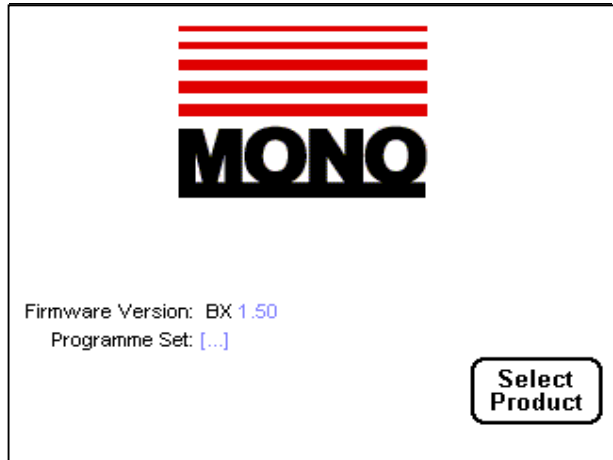

Fig 1

4. Press (4) and program list appears (see fig 2). (If oven has not been programmed go to section 9 - programming).

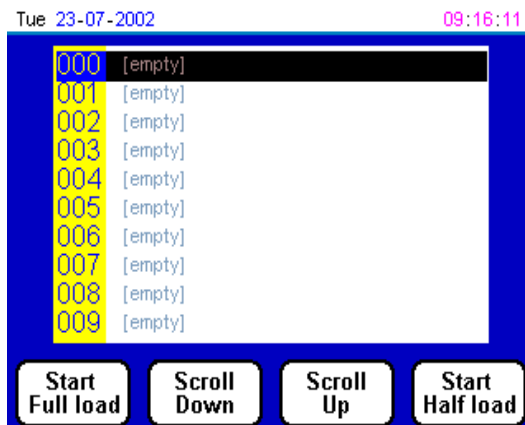

Fig 2

5. Highlight program required by pressing (2) = down list. (3) = up list
 (5)=10 places down and (6) = 10 places up (see fig 6)

6. Start heating oven by pressing (4) for ½ load bake and (1) for full load, and the following screen will appear. (fig 3)

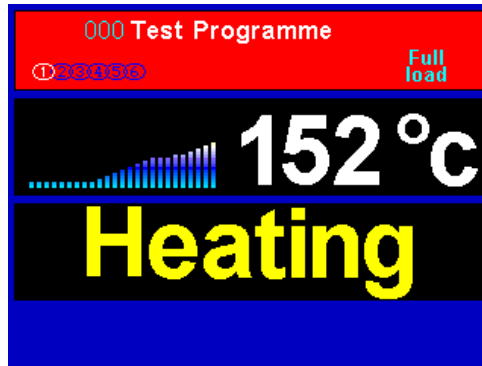

Fig 3

To stop heating press stop (o) at any time.

7. When oven is ready, the following screen will appear (fig 4). Load product and press start (4)

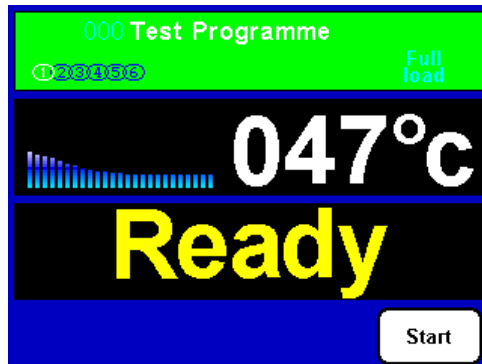

Fig 4

8. At the end of bake time, buzzer will sound, and (fig 5) will be displayed. Press stop (o)

and remove product. Shut door to conserve heat.

OR

press key 4 to increase bake by 2 minutes (press stop at any time to stop bake)



Fig 5

9. This will now take you back to program screen (Fig 2).
10. To bake in pre-heated oven, select new program with keys 2 and 3. Follow instructions 6 – 8.

NOTE: During heating (1) can be pressed at any time to check settings.
(Press (1) or wait 10 seconds to return to previous screen).

Until oven is up to temperature the display will show “ HEATING” when correct temperature is reached display will show “READY” the oven will keep to set temperature until the bake is started.

Oven will keep up to temperature of the last product baked or a new item on the program list if chosen.

9.0 BXC PROGRAMMING INSTRUCTIONS

1. Press stop (o) to get to first screen

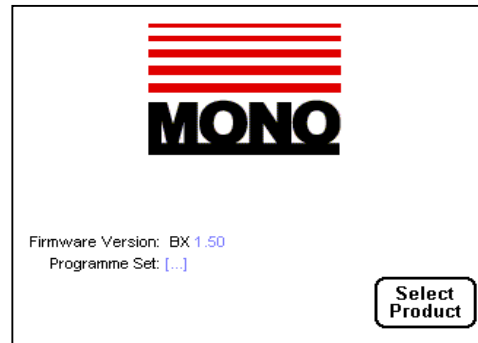

Fig 7

2. Press (2) for pass code screen Fig 8.

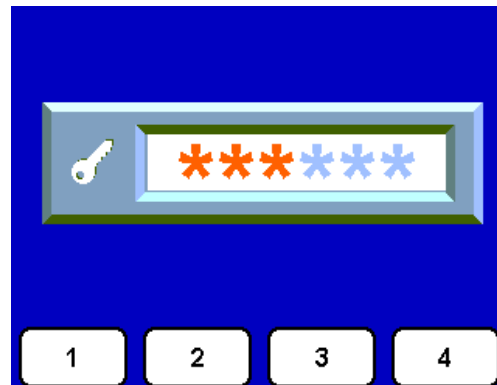

Fig 8

3. Enter pass code (default 111111). Fig 9 will appear.

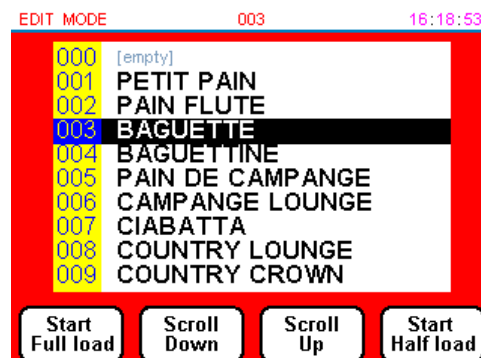

Fig 9

4. Press (4) for $\frac{1}{2}$ bake set-up or (1) for full bake set-up
All parameters can now be set.

The oven is capable of six different phases per bake and if a lower number is required, bake time can be left at “0” to leave that phase inoperative.

- To move **across** the screen press **(4)**
- To move **back** press **(1)**
- To **increase** value of parameter press **(3)**
- To **decrease** value of parameter press **(2)**

POWER LEVELS

TEMPERATURE

BAKE DURATION
(minutes)

STEAM DURATION
(seconds)

FAN CYCLES

FAN DWELL
(seconds)

DAMPER DELAY
(from start of bake phase)

Parameter	Phase 1	Phase 2	Phase 3	Phase 4	Phase 5	Phase 6
Temperature (°C)	142	200	250	180	150	150
Bake Duration (mins)	02	04	10	0	0	0
Steam Duration (secs)	05					
Fan Cycles	01	02	02	08	08	08
Fan Dwell (mins)	01	00	00	00	00	00

PROGRAM TITLE

Press (6) to go up alphabet, press (5) to go down alphabet. After each letter has been chosen press (4) to go to next position. If a mistake is made, pressing (1) will go back to previous position.

WHEN ALL PARAMETERS ARE COMPLETE
PRESS (stop) **THREE TIMES** TO SAVE THE SETTINGS.

REPEAT FOR EACH PROGRAM REQUIRED.

10.0 USING MONOLINK UPLOAD/DOWNLOAD SYSTEM SOFTWARE

Equipment required:

- P.C. floppy disk drive
- 9 ways D-type serial port
- Windows 95-2000
- Monolink up/download system
- Null modem cable (2 x 9 way D-type connector – both female)
- Approximately 2m long

Section 1. Getting Started

Connect the Null modem cable from the P.C (usually com 1) to the port on the control panel. Switch on your P.C and enter windows. Insert Mono floppy disc, double click on 'my computer' icon then double click on '(A) drive', double click on 'shortcut to Monolink.exe'. This will then progress you into the main screen as shown below:

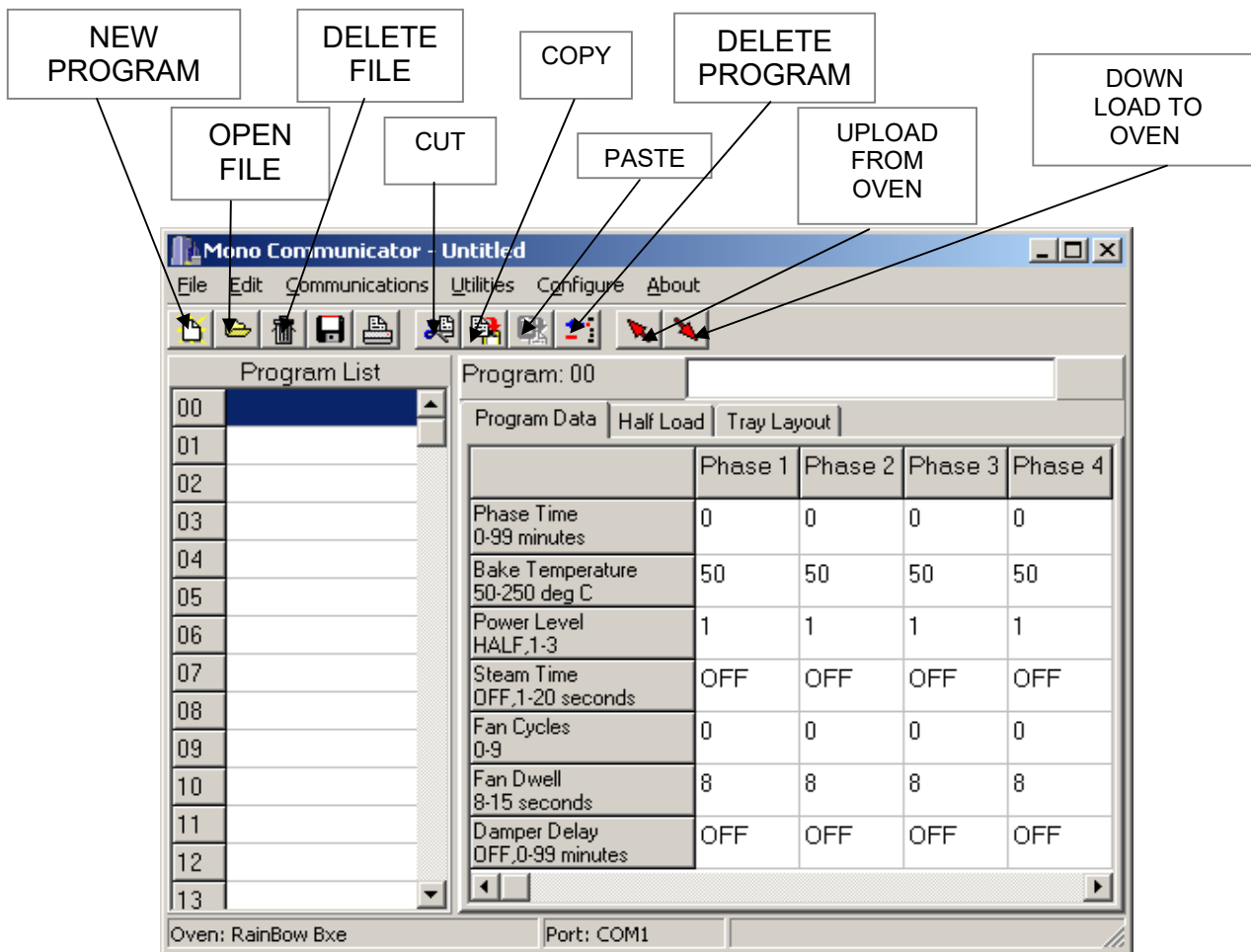

Figure 1

Section 2. Setting up

1. Choose 'Configure' and scroll down to 'Com port'
2. Then click on 'Com 1' oven type
3. Next click on 'Configure' scroll down to oven
4. Next click on 'Rainbow Bxe'

Section 3. Writing programs on your Personal computer (P.C)

Click on first box under the heading program list, (as can be seen in fig 2) enter your program name and select phase time, bake temperature, power level, steam time, fan cycles, fan dwell and damper delay. This can be repeated up to 99 times just by clicking on next box below. It is now important to save the file to disk.

(See section 4 saving)

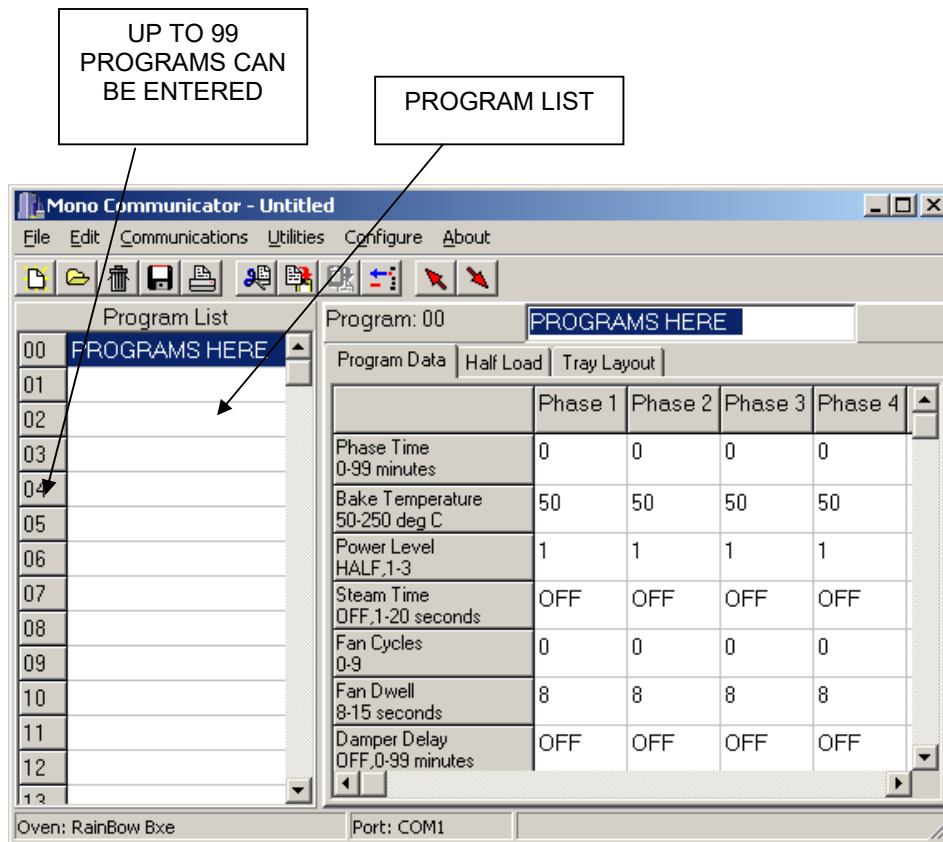

Figure 2

Section 4. Saving

Click on 'file' then scroll down to 'save as' and click on it, and the following box will appear, chose an appropriate drive and enter a suitable name for the file and press save.

It is from this screen that the files are given they names:

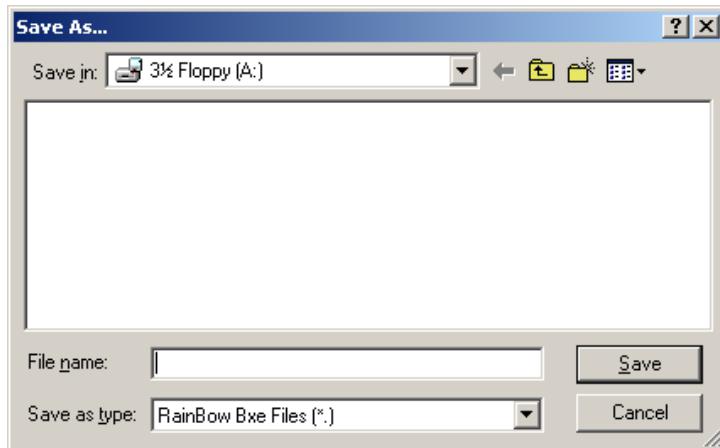

Figure 3

Section 5. To open, recall a folder and file

To recall a file or folder first point and press the 'file' button, scroll down until 'open' is highlighted then click once more. (Or click on 'open file' see figure 1)

The following window will appear:

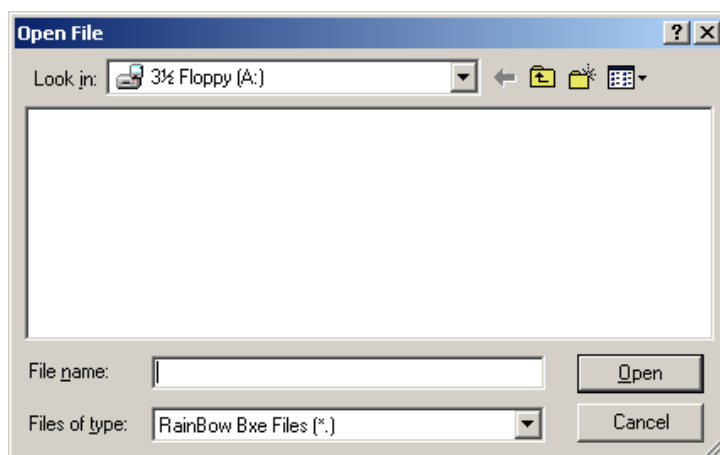

Figure 4

Click on the file needed, and press open, the file will then open in the Mono Communicator. (or enter the file name into the box).

Section 6. Transferring files from your PC to your smartbake controller

Before any file transfer can take place the folder you wish to transfer files from must be opened. To do this follows the instructions in **section 5 to open, recall a file or folder**.

Check that oven is switched on and in the following screen:

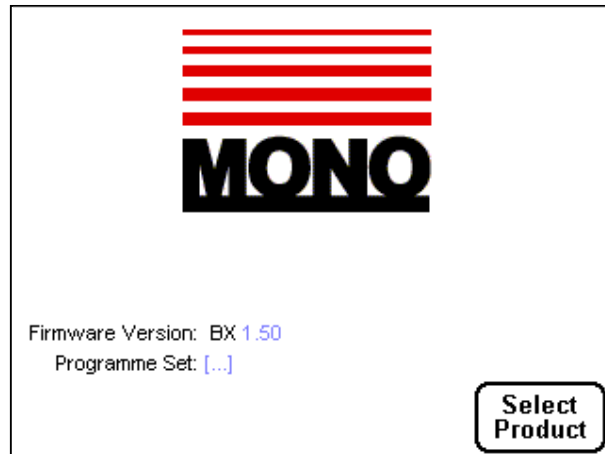

Figure 5

Also check that data transfer lead is properly connected

Uploading from oven

Check that oven is switched on and that data transfer lead is properly connected, and that **'figure 5'** is displayed.

Click the red up-arrow key or click on communications in the toolbar and select upload (from oven), and the following screen will appear:

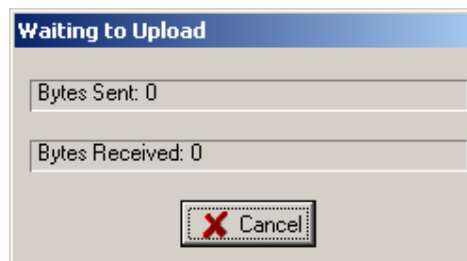

If during either uploading or downloading, the communications error window opens,

With the error message “Error in reply from controller” then check that the data transfer lead is connected correctly and that the oven is switched on and functioning normally.



Downloading from Computer (P.C)

Check that oven is switched on and that data transfer lead is properly connected, and that figure 5 is displayed.

Open file to be downloaded

Click the red up-arrow key or click on communications in the toolbar and select upload (from oven), and the following screen will appear:

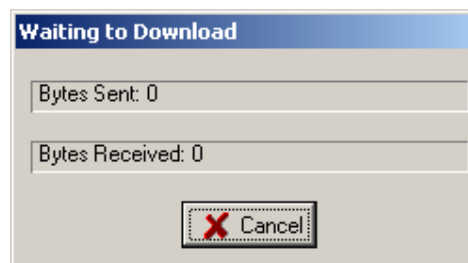

With the mono communicator window open and a program file open, individual bake programs can be cut pasted via the edit button in the toolbar.

11.0 MAINTENANCE

- Check for frayed or bare cables. The machine must not be used if frayed or bare cables are visible.
- Follow cleaning instructions

12.0 BULB REPLACEMENT

REPLACEMENT BULB = B857-94-007

In the event of a bulb failure, Instructions on how to change a bulb are as follows: -

- Ensure oven is isolated from mains supply and allow to cool.
- Remove screws (4 per light) and take glass, frame and gasket off lamp unit.

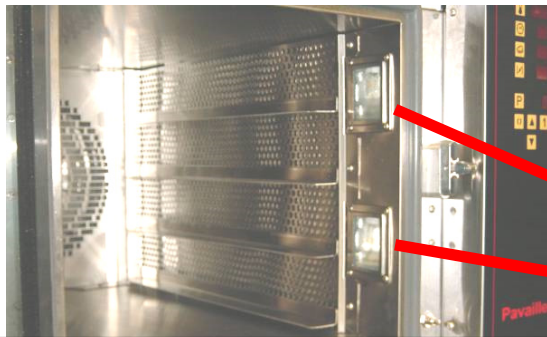

SCREWS

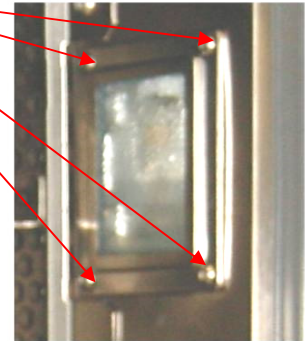

DO NOT TOUCH BULBS WITH BARE HANDS.
USE A CLOTH OR GLOVES TO STOP ANY MARKS THAT WILL CAUSE HOT SPOTS AND PREMATURE BULB FAILURE.

- Remove bulb by pulling in direction of arrow and replace with new bulb.

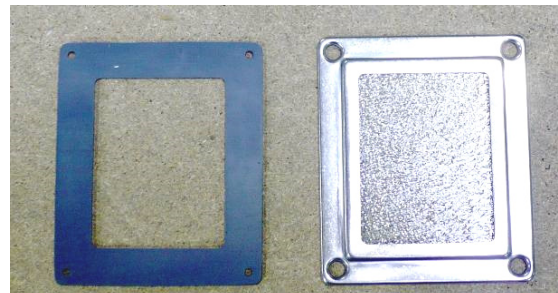

GASKET

Pt No.B721-67-008

GLASS AND FRAME

Pt No.B721-67-010

Pt No.B721-67-009

- Refit glass front taking care that gasket is in position around stainless steel frame. Re-connect oven and test.

13.0 STEAM SYSTEM MAINTENANCE

- If it is noticed that the steaming operation has deteriorated, perhaps due to hard water scaling, please contact your oven supplier

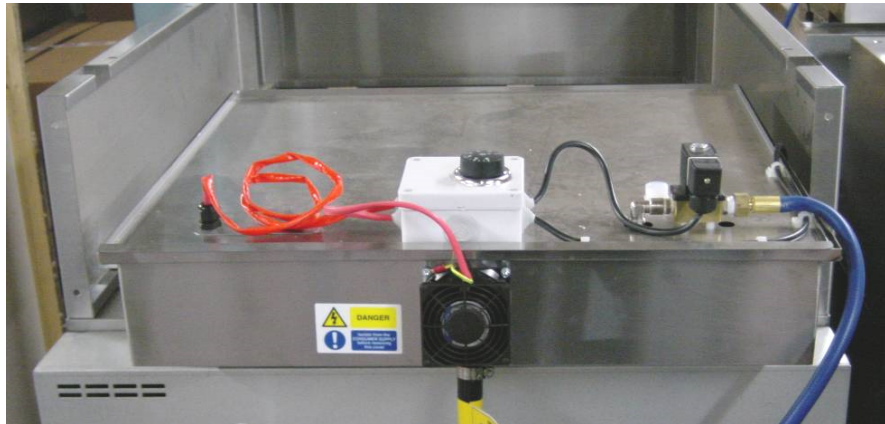

CONDENSER UNIT

INDEX

INTRODUCTION	PAGE 31
DIMENSIONS	PAGE 32
SPECIFICATIONS	PAGE 33
INSTALLATION	PAGE 34
SAFETY	PAGE 36
OPERATION	PAGE 37
SPARES	PAGE 38
ELECTRICAL INFORMATION	SEE ELECTRICS MANUAL

INTRODUCTION

The condenser can be fitted to any Bx oven or stacked Bx ovens as required. With thermostatic control it can be adjusted to operate in most ambient temperatures. Simple water connection (washing machine type fitting) and a hose to drain are all that is required to operate efficiently.

Steam is drawn from the fluepipe of the oven through a thermostatically controlled water cooled chamber and condenses to drain away. When the cooling water reaches a set temperature it is automatically replaced with cold water to keep the condensing process as efficient as possible.

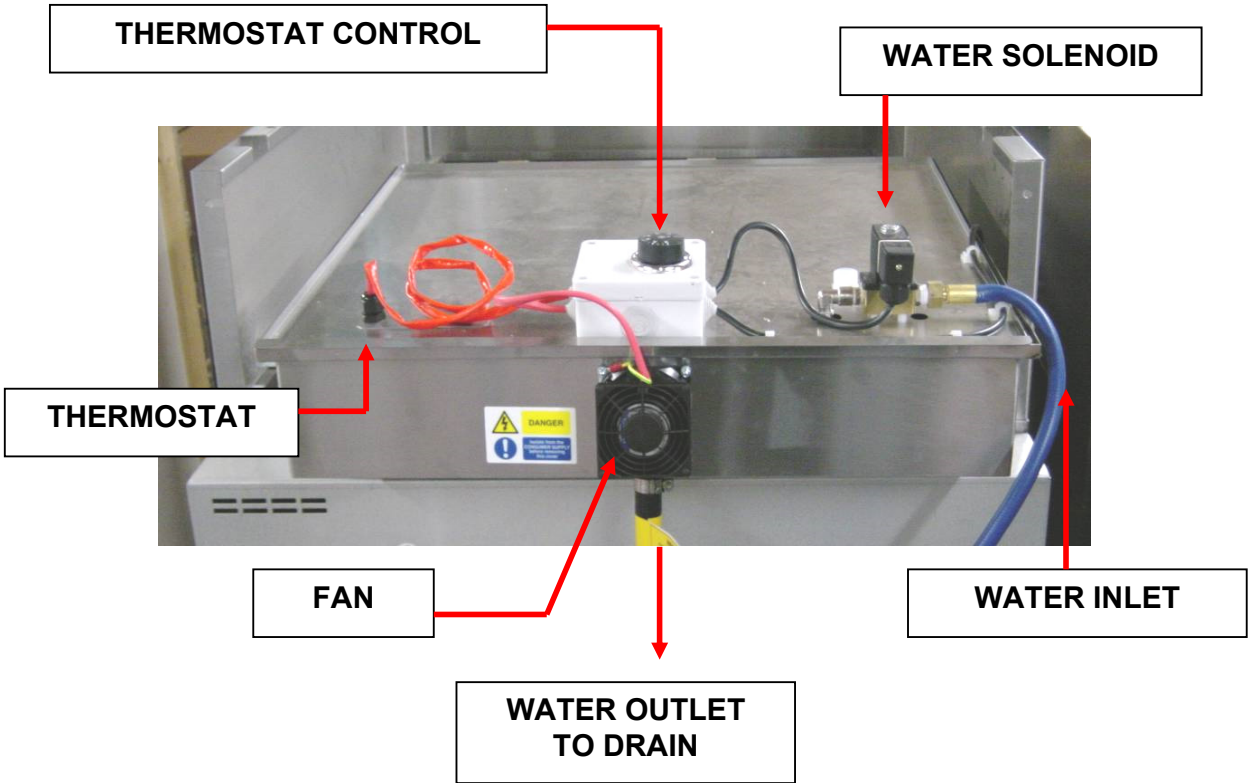

DIMENSIONS

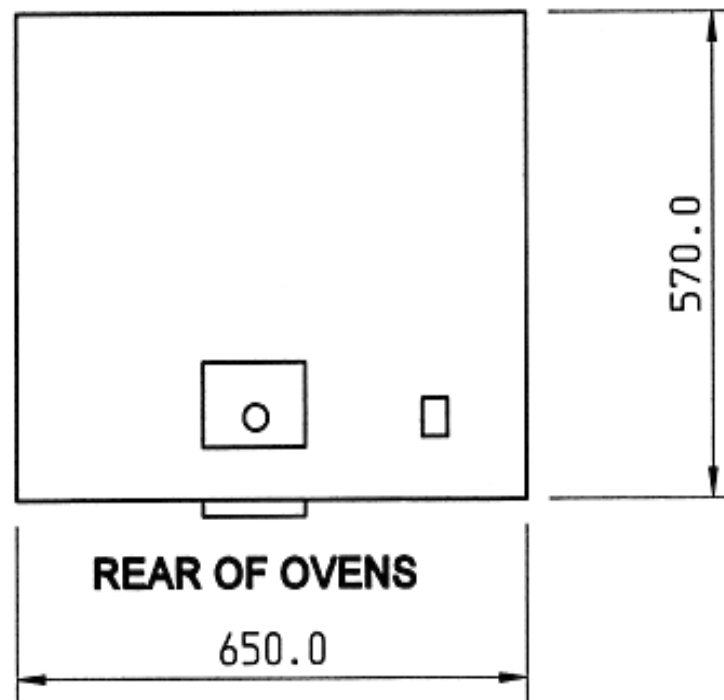
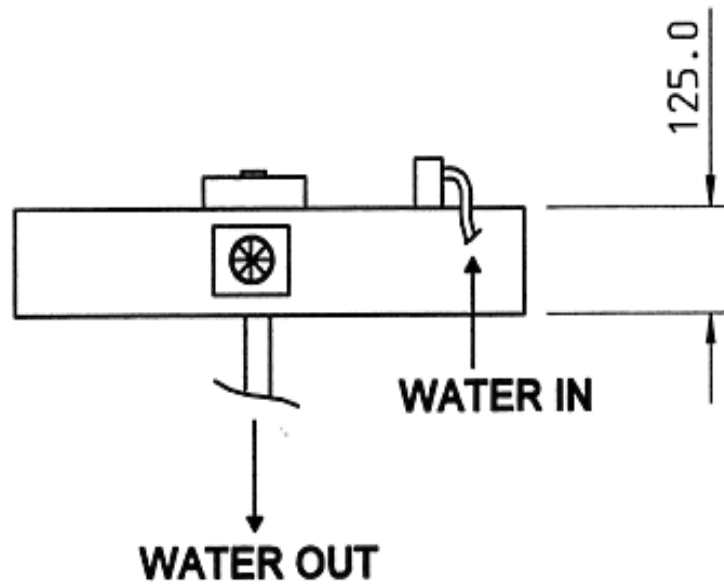

SPECIFICATIONS

POWER 230volts, 1 phase, 50hz,
21watts
Wired to oven electrical panel.

WATER Washing machine type connection to normal water supply
via steam water connection to oven(s).

NOISE Less than 85dB

WEIGHT Approx 18kg

INSTALLATION

BEFORE INSTALLING ENSURE THAT ALL POWER IS DISCONNECTED AND THE OVEN IS COOL

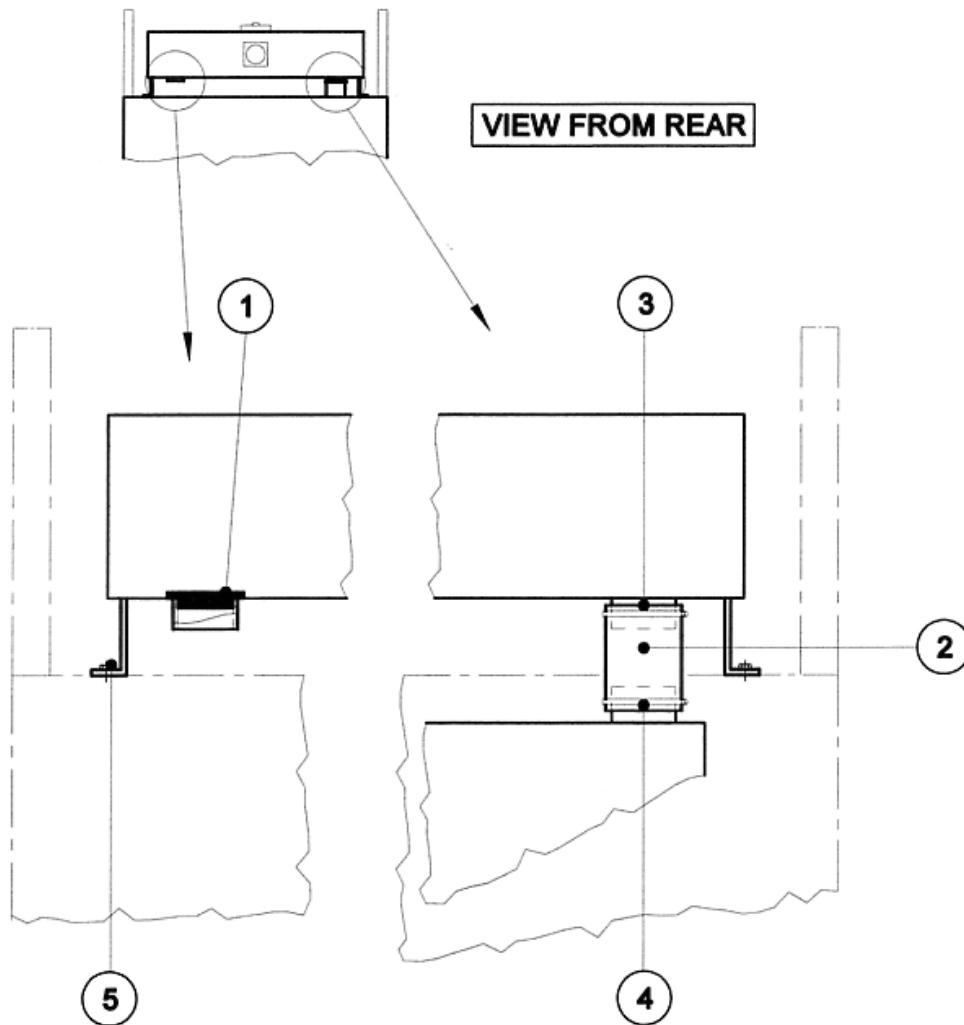

1. Before fitting the main condenser assembly, insert blanking plug (1) into lower hole that will not be required for the hand of oven being used.
2. Connect tube (2) to the spigot and retain with worm-drive clip (3).

NOTE

If fixing holes are not present on the top sheet of the oven, they should be marked and drilled at this stage.

Position condenser correctly and mark hole positions (*centre of each slot*). Remove condenser and drill holes of 6.5mm diameter at 4 positions.

3. Place condenser in position ensuring that the tube (2) passes through the hole in the top of the oven and worm drive clip (4), then over spigot of the damper assembly on the oven.
4. Tighten worm-drive clip (4).
5. Fasten condenser unit to top of oven with M6 x 12mm long hex head screws and washers in 4 positions.
(If holes have been drilled, nuts will have to be used also).
6. Connect wiring, depending on whether the oven is 4 tray or 10 tray, as shown in electrical section of this manual.
7. Connect drain hose to a suitable drain.
8. Attach water tap bracket to frame of base as shown and fasten water hose to a water supply. *(A tee pipe must be used on double ovens)*

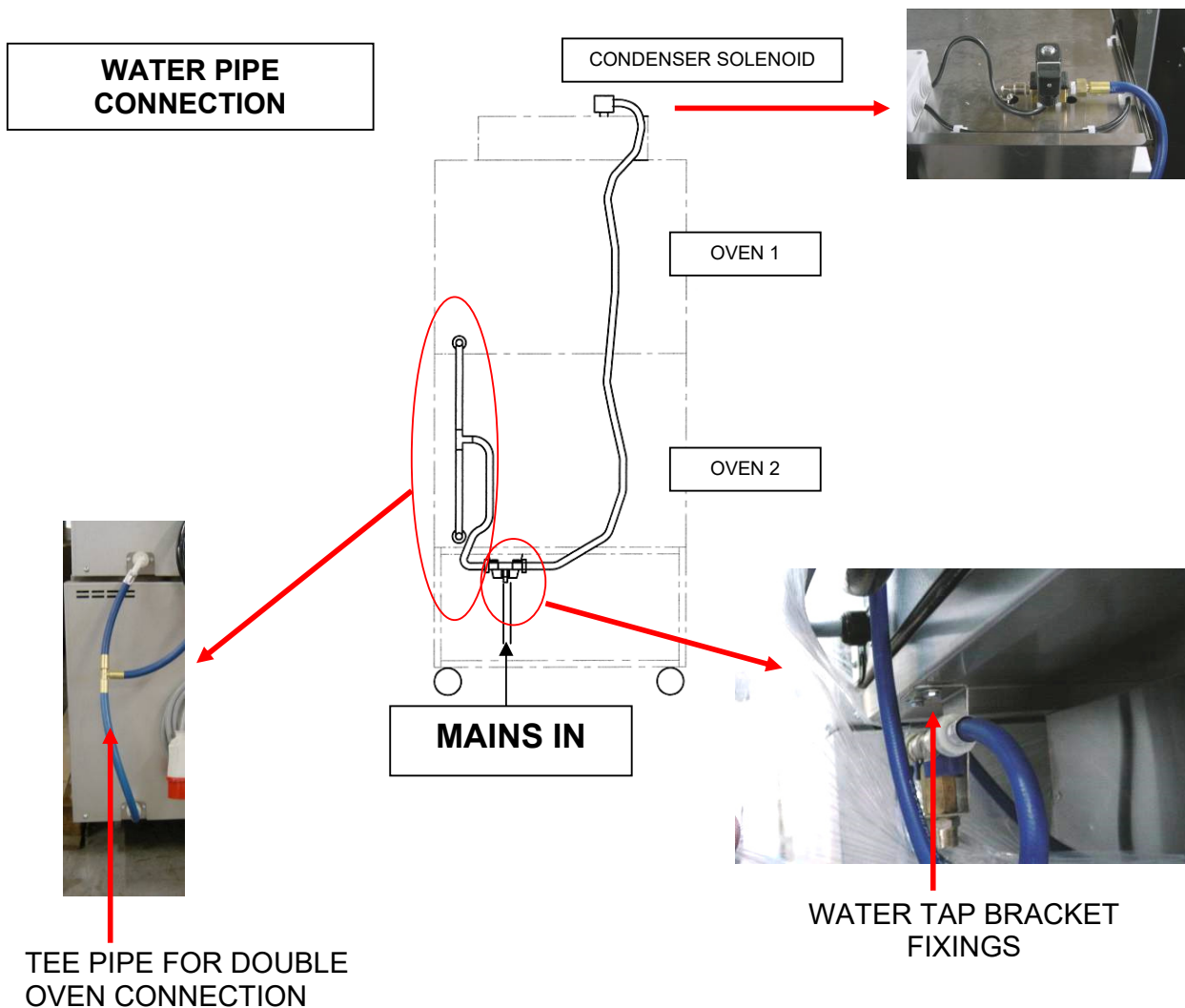

SAFETY

**BEFORE INSTALLING ENSURE THAT ALL POWER IS DISCONNECTED
AND THE OVEN(S) IS COOL**

1. All repairs and maintenance of electrical units must be carried out by authorised electricians; even then, electrical access panels must not be opened unless the mains supply to the oven is isolated.
2. All connections to the oven must be made in accordance with the statutory requirements of the country of installation.
3. While the oven is in operation (and for some time after use), **it is inadvisable to touch the condenser or the surrounds because of conducted heat.**
4. The condenser must be operated as described in this manual.
5. Only **MONO** spare parts should be used on this condenser.
6. The construction of the condenser must not be changed.

OPERATION

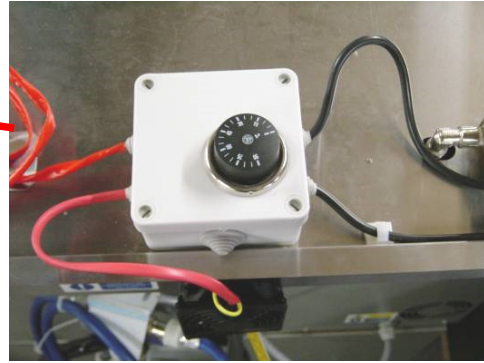
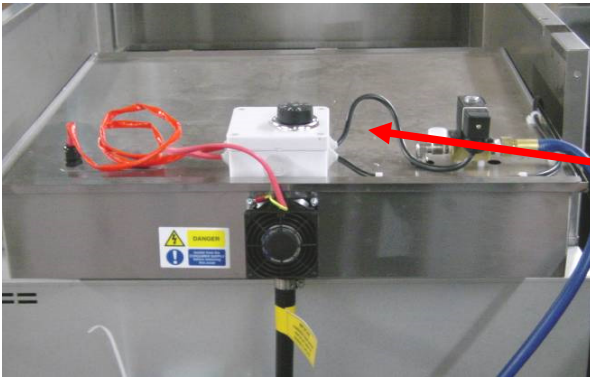

SETTING POSITION

1. Ensure that the water is connected correctly and the oven power is on.
2. The thermostat control should be adjusted to the required position.

It is suggested that as a starting point the thermostat is set at 60.

It can then be adjusted down if the performance drops or adjusted up if it is found that the water is being replaced too often.

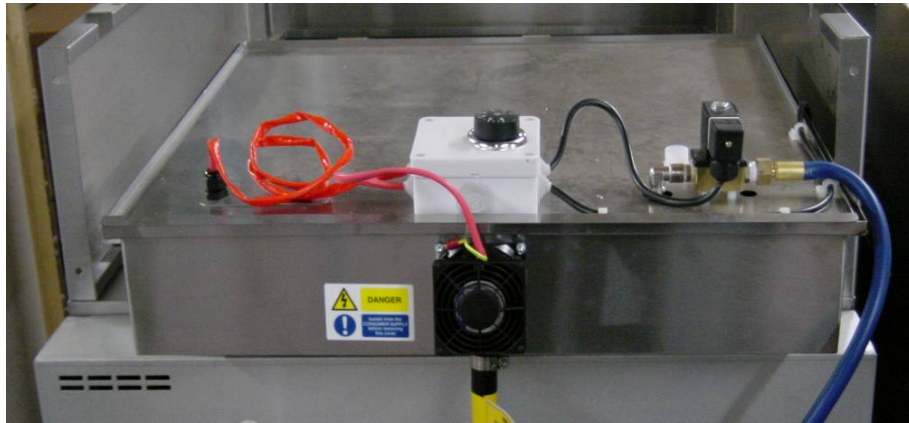

SPARES INFORMATION

FOR ENGINEERS USE ONLY.

DO NOT ATTEMPT ANY ALTERATIONS.
IF IN DOUBT, CONTACT MONO EQUIPMENT FOR ADVICE

CONDENSER UNIT MAIN PARTS

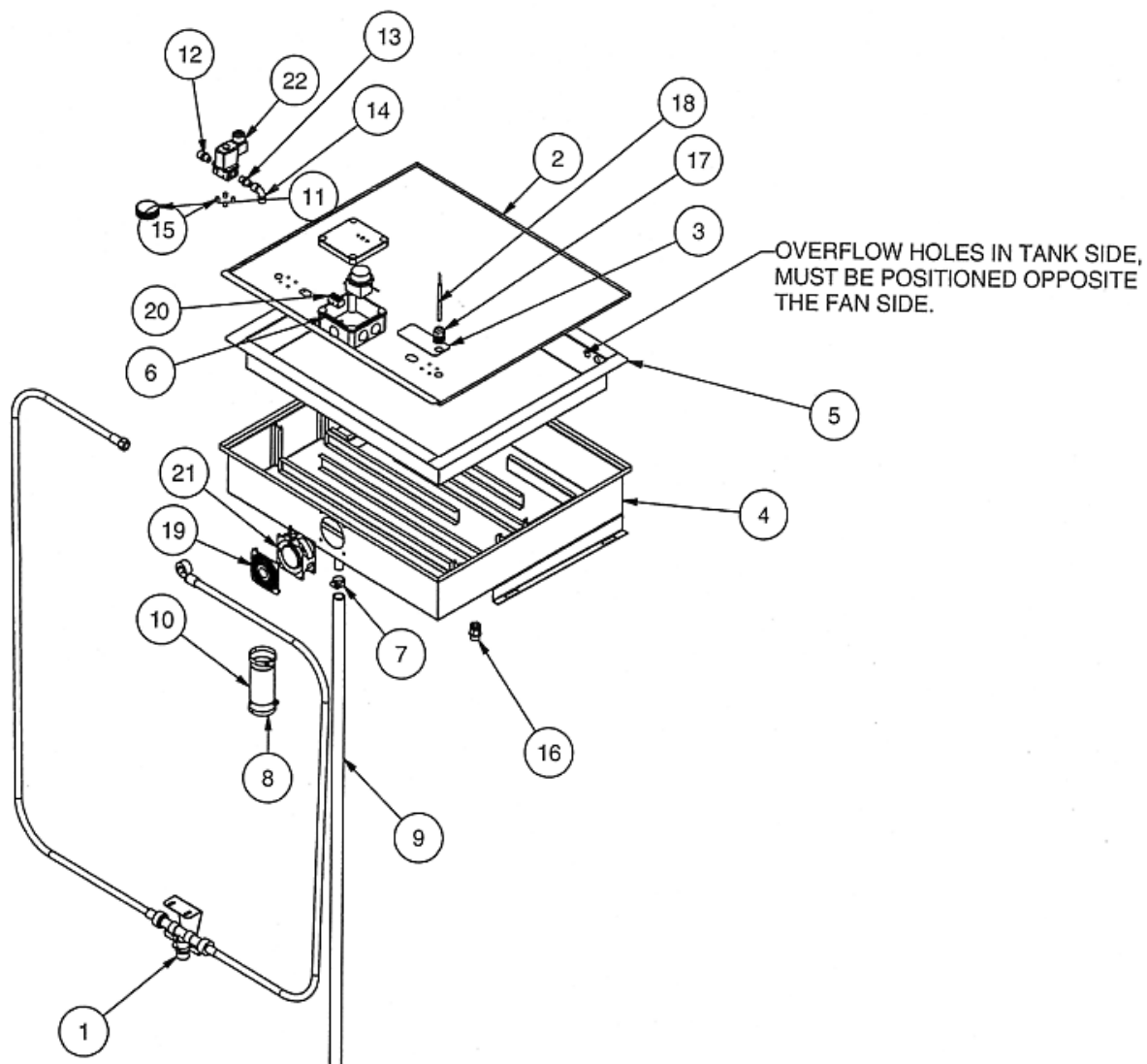

ITEM	PART No.	DESCRIPTION	QTY
①	150-07-01300	INLET WATER CONTROL UNIT	1
②	150-19-01700	TOP SHEET	1
③	150-19-02300	COVER PLATE	1
④	150-19-02600	BASE TRAY	1
⑤	150-19-02700	WATER TANK	1
⑥	150-25-07100	JUNCTION BOX	1
⑦	A900-01-196	WORM DRIVE CLIP	1
⑧	A900-01-271	WORM DRIVE CLIP	2
⑨	A900-23-004	DRAIN TUBE (2 METRES)	1
⑩	A900-23-027	FLEXIBLE TUBE	1
⑪	A900-27-187	PLUG INSERT	1
⑫	A900-34-191	REDUCER ¼" BSP MALE X 3/8" BSPT MALE	1
⑬	A900-34-244	REDUCER ¼" BSP MALE X ¼" BSPT MALE	1
⑭	A900-34-245	ELBOW	1
⑮	B811-33-001	SPACER	4
⑯	B839-17-003	CABLE GLAND TYPE 251	1
⑰	B842-17-005	CABLE GLAND TYPE 206-6096	1
⑱	B842-30-003	THERMOSTAT	1
⑲	B842-40-002	FAN GUARD	1
⑳	B842-50-005	PORCELAIN CONNECTING BLOCK	1
㉑	B869-75-033	FAN	1
㉒	B867-83-011	SOLENOID VALVE	1

If a fault arises, please do not hesitate to contact the
Customer Service Department, quoting the **machine serial number**
on the silver information plate of the machine and on the front cover of this manual

SPARES and SUPPORT:

MONO

Queensway
Swansea West Industrial Estate
Swansea. SA5 4EB UK

email: spares@monoequip.com

Web site: www.monoequip.com

Spares Tel. +44(0)1792564039

Fax. 01792 561016

□ OVEN DISPOSAL

CARE SHOULD BE TAKEN WHEN THE MACHINE COMES TO THE END OF ITS WORKING LIFE. ALL PARTS SHOULD BE DISPOSED OF IN THE APPROPRIATE PLACE, EITHER BY RECYCLING OR OTHER MEANS OF DISPOSAL THAT COMPLIES WITH LOCAL REGULATIONS.

(IN UK, ENVIRONMENTAL PROTECTION ACT 1990 APPLIES)