

www.monoequip.com



Bx OVEN

ELECTRICAL INFORMATION

CLASSIC

**FOR ENGINEERS USE ONLY.
DO NOT ATTEMPT ANY ALTERATIONS.
IF IN DOUBT, CONTACT MONO FOR ADVICE**

ELECTRICAL SAFETY AND ADVICE REGARDING SUPPLEMENTARY ELECTRICAL PROTECTION:

Commercial bakeries, kitchens and food service areas are environments where electrical appliances may be located close to liquids, or operate in and around damp conditions, or where restricted movement for installation and service is evident.

The installation and periodic inspection of the appliance should only be undertaken by a qualified, skilled and competent electrician, and connected to the correct supply suitable for the load as stipulated by the appliance data label.

The electrical installation and connections should meet the necessary requirements of the local electrical wiring regulations and any electrical safety guidelines.

We Recommend:

- Supplementary electrical protection with the use of a residual current device (RCD)
- Fixed wiring appliances incorporate a locally situated switch disconnecter to connect to, which is easily accessible for switching off and safe isolation purposes. The switch disconnecter must meet the specification requirements of IEC 60947.

Your attention is drawn to:

BS 7671:2018 – Guidance Note 8 – 8.13 : Other locations of increased risk

It is recognised that there may be locations of increased risk of electrical shock other than those specifically addressed in Part 7 of BS 7671. Examples of such locations could include laundries where there are washing and drying machines in close proximity, and water is present, and commercial kitchens with stainless steel units, where once again, water is present. Where, because of the perception of additional risks being likely, the installation designer decides that an installation or location warrants further protective measures, the options available includes:

- Automatic Disconnection of Supply (ADS) by means of a residual current device having a residual operating current not exceeding 30 mA;
- Supplementary protective equipotential bonding; and
- Reduction of maximum fault clearance time.

The provision of RCDs and supplementary bonding must be specified by the host organisation's appointed installation designer or electrical contractor and installed by a suitably qualified and competent electrician so as to comply with Regulations 419.2 and 544.2.



The supply to this machine must be protected by a **30mA RCD**

CONTENTS

BX CLASSIC WIRING DIAGRAMS

SECTION 1

FG149/150

10 TRAY CLASSIC

PAGE 3

M150E25-04200	COMPONENTS
M150E25-04100	PANEL LAYOUT
M150E25-04300	PCB OUTPUTS
M150E25-50800	PCB CONNECTIONS
M150E25-04600	INTERIOR LIGHT AND POWER CIRCUIT
M150E25-04400	PCB INPUTS
M150E25-03200	MOTOR POWER CIRCUIT
M150E25-03300	HEATING POWER CIRCUIT
M150E25-03400	FAN CONNECTIONS AND ELEMENT WIRING

SECTION 2

FG156

2 TRAY CLASSIC

PAGE 13

M156E25-13500	COMPONENTS
M156E25-13000	CONTROL AND POWER CIRCUIT
M156E25-13600	PCB OUTPUTS
M156-25-50500	PCB INPUTS
M156-25-50800	PCB CONNECTIONS
M156E25-50200	COMPONENTS (1 PHASE)

SECTION 3

FG153/158/159 4 TRAY, 3 PHASE CLASSIC

M159E25-11300	COMPONENTS (159 ONLY)
M158E25-52000	COMPONENTS (153/158 ONLY)
M158E25-50800	PCB CONNECTIONS
M158E25-50500	PCB INPUTS
M158E25-50100	PCB OUTPUTS
M158E25-20700	CONTROL CIRCUIT
M158E25-01800	POWER CIRCUIT
M158E25-01900	FAN CONNECTIONS AND ELEMENT WIRING

PAGE 20

SECTION 4

FG153/158/159 4 TRAY, 1 PHASE CLASSIC

M158E25-51200	COMPONENTS (153/158 ONLY)
M159E25-11200	COMPONENTS (159 ONLY)
M158E25-51400	PCB OUTPUTS
M158-25-51500	PCB CONNECTIONS
M158E25-50500	PCB INPUTS
M158E25-20700	CONTROL CIRCUIT
M158E25-51300	POWER CIRCUIT
M158E25-52200	FAN CONNECTIONS AND ELEMENT WIRING

PAGE 29

CONDENSER (IF FITTED)

PAGE 38

FG149/150 CLASSIC 10 TRAY

M150E25-04200	COMPONENTS
M150E25-04100	PANEL LAYOUT
M150E25-04300	PCB OUTPUTS
M150E25-04500	PCB CONNECTIONS
M150E25-04600	INTERIOR LIGHT AND POWER CIRCUIT
M150E25-04400	PCB INPUTS
M150E25-03200	MOTOR POWER CIRCUIT
M150E25-03300	HEATING POWER CIRCUIT
M150E25-03400	FAN CONNECTIONS AND ELEMENT WIRING

SECTION 1

FOR ENGINEERS USE ONLY.
DO NOT ATTEMPT ANY ALTERATIONS.
IF IN DOUBT, CONTACT MONO FOR ADVICE

IF IN ANY DOUBT - ASK

DRAWING PT-Ref	DESCRIPTION	MONO PART NUMBER
PT-2	CONTROL CIRCUIT M.C.B.	8872-22-062
PT-4a	FAN MOTOR OVERLOAD UNIT N'1 (TOP)	8801-03-020
PT-4b	FAN MOTOR OVERLOAD N'1 AUXILIARY CONTACT	8801-14-012
PT-5a	FAN MOTOR OVERLOAD UNIT N'2 (BOTTOM)	8801-03-020
PT-5b	FAN MOTOR OVERLOAD N'2 AUXILIARY CONTACT	8801-14-012
PT-10a	FAN MOTOR CONTACTOR N'1-FORWARD (TOP MOTOR)	8801-08-031
PT-10b	FAN MOTOR CONTACTOR N'1-REVERSE (TOP MOTOR)	8801-08-031
PT-11a	FAN MOTOR CONTACTOR N'2-FORWARD (BTM MOTOR)	8801-08-031
PT-11b	FAN MOTOR CONTACTOR N'2-REVERSE (BTM MOTOR)	8801-08-031
PT-14	24V DC POWER SUPPLY UNIT	8801-93-005
PT-15	HEATING ELEMENT CONTACTOR	8801-08-020
PT-17	{ DAMPER SOLENOID (L/H) DAMPER SOLENOID (R/H)	{ 8749-83-003 8749-83-004
PT-18	FAN MOTOR UNIT N'1 (TOP MOTOR)	8720-74-005
PT-19	FAN MOTOR UNIT N'1 (BOTTOM MOTOR)	8720-74-005
PT-20	WATER SOLENOID	150-07-004.00
PT-21	OVERHEAT THERMOSTAT N'1 (TOP)	8888-30-014
PT-23	OVEN THERMOCOUPLE	8873-95-002
PT-24	MAIN P.C.B.	8705-97-013
PT-26	MAIN OFF/ON SWITCH	8836-07-004
PT-27	DOOR SWITCH	8842-07-037
PT-28B	INTERIOR LIGHT BULB	8855-94-009
PT-30	8KW ELEMENT OVENS ONLY	
PT-31	HEATING ELEMENT UNIT N'1 (TOP)	8847-04-068
PT-31	HEATING ELEMENT UNIT N'2 (BOTTOM)	8847-04-068
PT-30	HEATING ELEMENT UNIT N'1 (TOP)	8847-04-073
PT-31	HEATING ELEMENT UNIT N'2 (BOTTOM)	8847-04-073
PT-30	7KW ELEMENT OVENS ONLY	
PT-31	HEATING ELEMENT UNIT N'1 (TOP)	8847-04-067
PT-31	HEATING ELEMENT UNIT N'2 (BOTTOM)	8847-04-067
PT-30	HEATING ELEMENT UNIT N'1 (TOP)	8847-04-074
PT-31	HEATING ELEMENT UNIT N'2 (BOTTOM)	8847-04-074
PT-34	REAR FAN UNIT	8869-75-018
PT-35	REAR FAN UNIT FUSE	8842-85-025
PT-36	AUX POWER OUTLET	8970-06-001
PT-37	AUX POWER OUTLET FUSE	8842-85-039

Bx oven range elect + conden
classic halogen lights RevA21 07-04-21

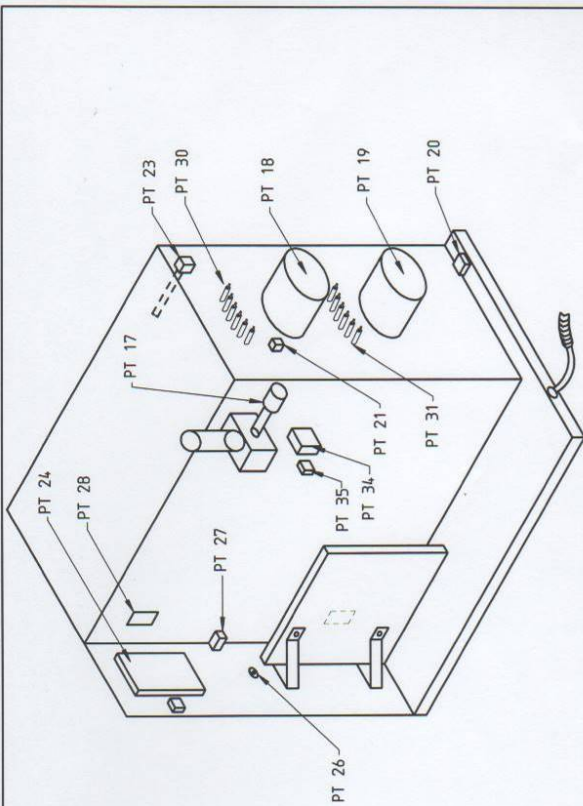



REV	SIG	DATE	REVISION	ECH NO.
M	JC	02-05-19	PT-27 WAS 8842-07-023	8X-001-18-19
L	JC	27-11-18	PT-18 & PT-19 WERE 8720-74-001	8X-009-17-18
K	RAC	11-11-09	PARTS 1, 8, 28A DELETED. 28B WAS 8857-94-004	B15/09
J	JC	29-01-09	PT27 WAS ASSY 154-25-01200 (8801-11-001)	195/08
I	RAC	29-03-07	PT22 O/HEAT THERMOSTAT DELETED. PT36/37 ADDED	2946
H	JC	30-10-06	PT-17 WAS 8749-83-001 & 8749-83-002	2868
G	RAC	31-10-05	8859- NOW 8801-	2573
F	JC	27-7-05	PT-23 WAS 8873-95-001	2525
E	JC	13-6-05	PT-14 WAS 8705-93-006	2483
D	JC	7-4-05	PT-28A WAS 8721-67-001	2435
C	JC	22-11-04	PT-26 WAS 8842-07-014	2329
B	JC	22-11-04	PT-34 WAS 8869-75-023	2318
A	JC	14-2-03	EXISTING SMALL FAN DELETED (IN CONJUNCTION WITH ECH 1925)	1927

MONO EQUIPMENT		REVISION	
QUEENSWAY SWANSEA WEST IND PARK SWANSEA, SIS REB.		TITLE:	
TEL: (01782) 561254 FAX: (01782) 561016		ELECTRICAL COMPONENTS LAYOUT	
ELECTRICAL SPECIFICATIONS:-		DRAWN: JC	
380V/4.15V 3PH+N 50Hz		DATE: 25-1-01	
		DRAWING NO: M150E25-04200	
		REVISION: ELECTRICALLY APPROVED BY:-	
		REV: H	

COPYRIGHT © 1998 - THIS DESIGN/DRAWING IS THE PROPERTY OF MONO EQUIPMENT LTD. AND MUST NOT BE REPRODUCED, COPIED, NOR ITS CONTENTS DIVULGED WITHOUT PRIOR WRITTEN PERMISSION.

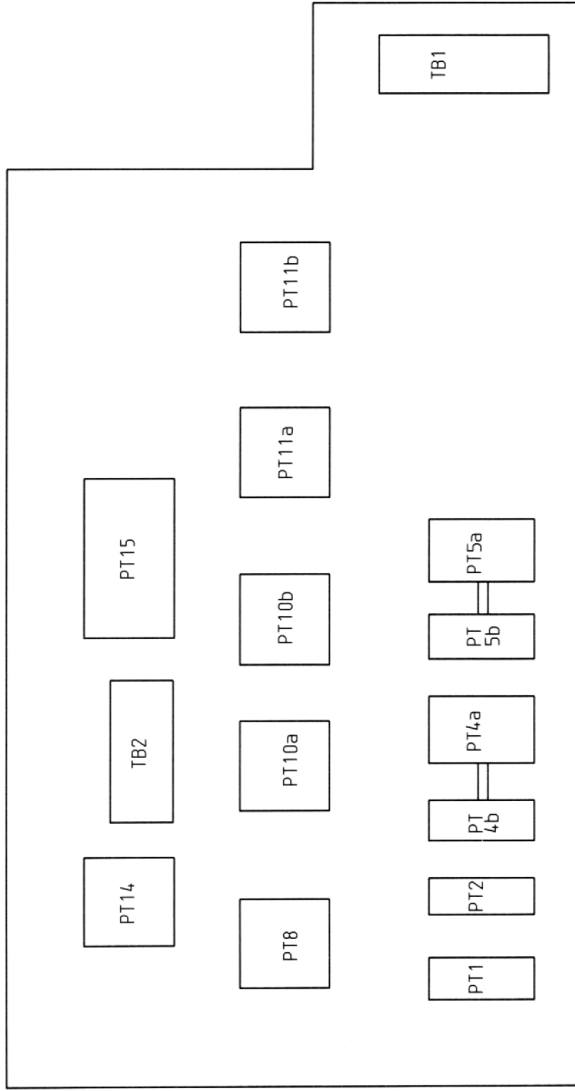
IF IN ANY DOUBT - ASK



REV	SIG	DATE	REVISION	ECN NO.
 MONO EQUIPMENT QUEENSWAY SWANSEA WEST IND PARK SWANSEA SA5 4EB TEL: (01792) 581234 FAX: (01792) 581016			TITLE: 10 TRAY OVEN WITH FAN REVERSING MAIN CONTROL PANEL LAYOUT	
ELECTRICAL SPECIFICATIONS:-			DRAWN: JC ELECTRICALLY APPROVED BY:- P. BOYLES	
COPYRIGHT © 1998 - THIS DESIGN/DRAWING IS THE PROPERTY OF MONO EQUIPMENT LTD. AND MUST NOT BE REPRODUCED. COPIED. NOR ITS CONTENTS DIVULGED WITHOUT PRIOR WRITTEN PERMISSION.			DATE: 24-1-01 DRAWING NO. M150E25-04.100 REV: -	

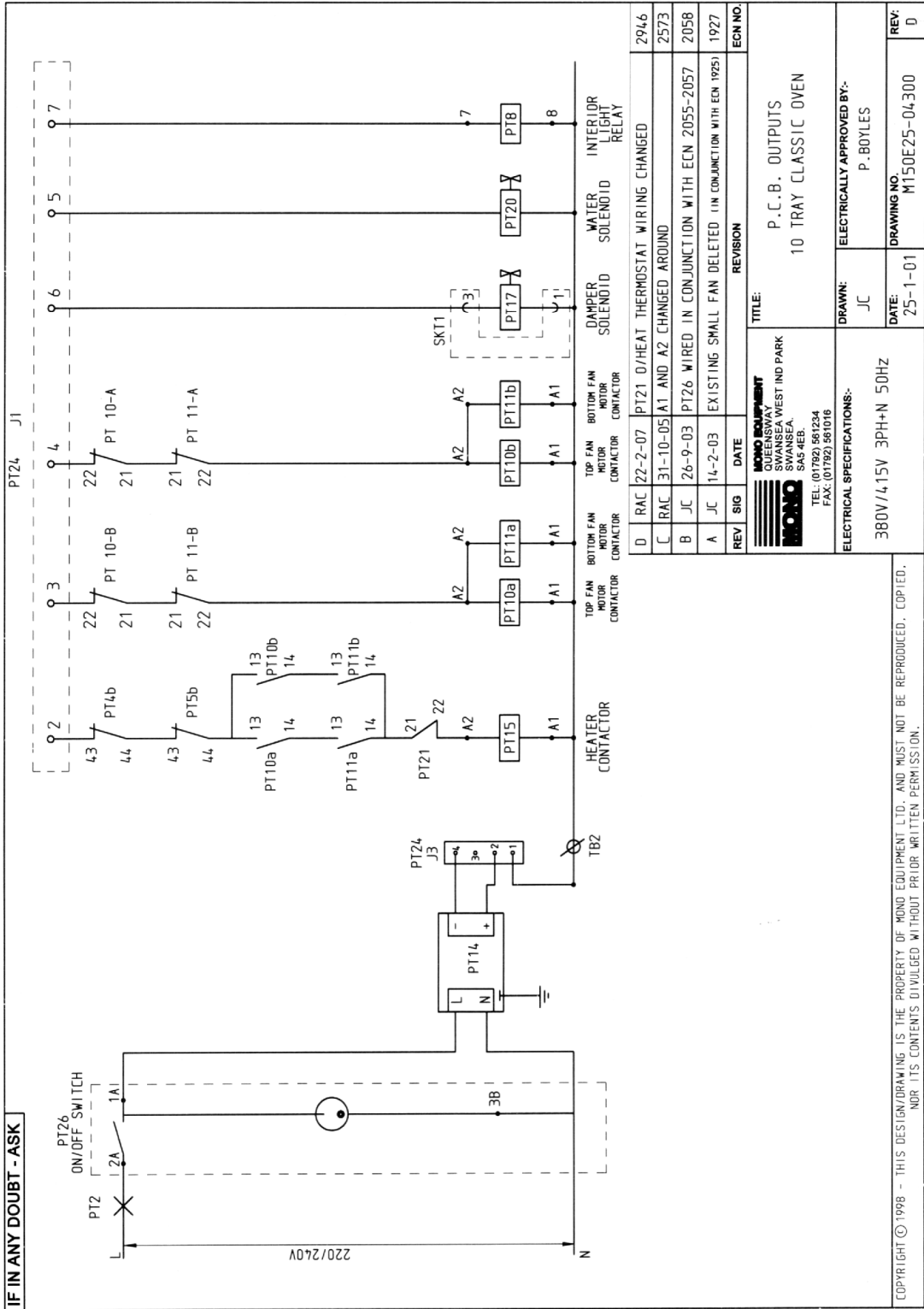

CONTROLLER BOARD AS VIEWED FROM COMPONENT SIDE
'CLASSIC' OVEN CONTROLLER

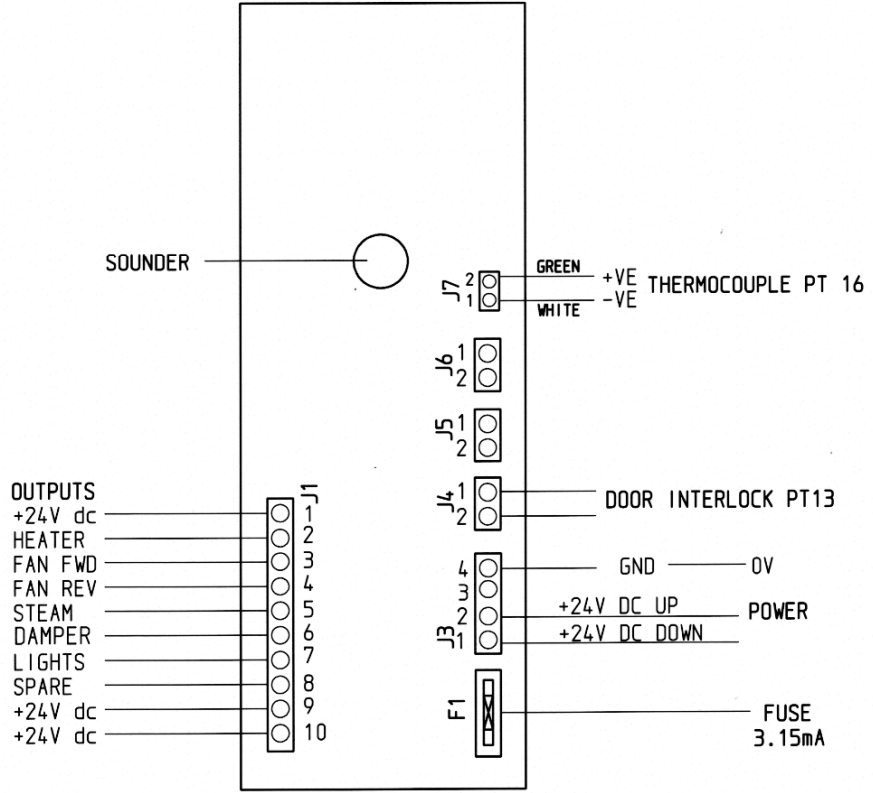

D	RAC	4-11-16	PICTORIAL CHANGES. BOARD WAS B705-97-013 NOW B705-97-027	BX-006-16-17
C	JC	24-1-03	DELETE SMALL COOLING FAN (IN CONJUNCTION WITH ECN 1927)	1925
B	JC	22-1-03	ADD WIRING FOR REAR FAN UNIT	1927
A	JC	22-2-01	RE-ARRANGE POWER CIRCUIT WIRES TO PCB	14/19
REV	SIG	DATE	REVISION	ECN NO.

 <p>MONO EQUIPMENT QUEENSWAY SWANSEA WEST IND PARK SWANSEA. SA5 4EB. TEL: (01792) 561234 FAX: (01792) 561016</p>	<p>TITLE: MAIN P.C.B. CONNECTIONS 4 TRAY CLASSIC OVEN</p>	
	<p>DRAWN: MT</p>	<p>ELECTRICALLY APPROVED BY:-</p>
<p>ELECTRICAL SPECIFICATIONS:-</p>	<p>DATE: 1-12-98</p>	<p>DRAWING NO. M158E25-50800</p>
		<p>REV: D</p>

IF IN ANY DOUBT - ASK

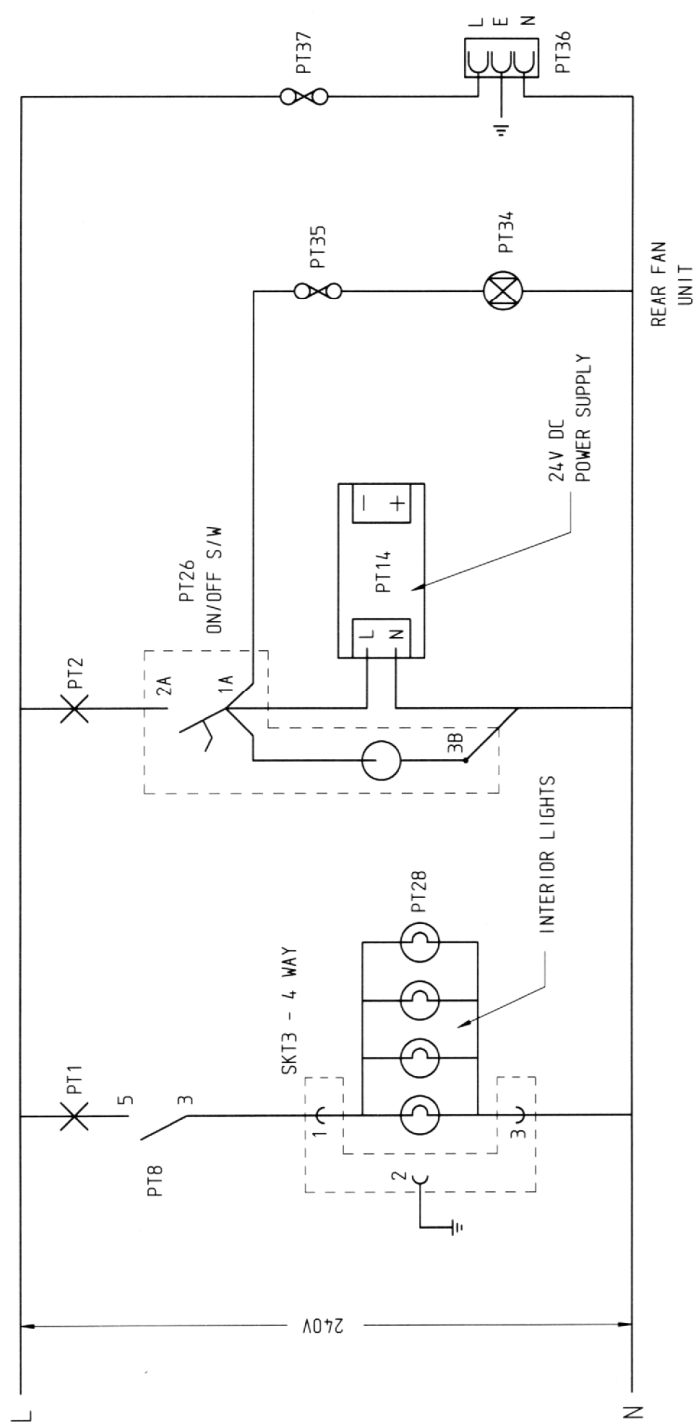

REV	SIG	DATE	REVISION	ECN NO.
C	RAC	22-2-07	PT36 & PT37 ADDED	2946
B	JC	26-9-03	PT26 WIRED IN CONJUNCTION WITH ECN 2055-2057	2058
A	JC	14-2-03	EXISTING SMALL FAN DELETED (IN CONJUNCTION WITH ECN 1925)	1927

<p>MONO EQUIPMENT QUEENSWAY SWANSEA WEST IND PARK SWANSEA, S.A.S. MER. TEL: (01792) 861234 FAX: (01792) 861016</p>	<p>TITLE: INTERIOR LIGHT & POWER SUPPLY CIRCUIT CLASSIC 10 TRAY OVEN</p>
<p>ELECTRICAL SPECIFICATIONS:- 380/415V 3PH+N 50HZ</p>	<p>DRAWN: JC</p>
<p>DATE: 12-2-03</p>	<p>ELECTRICALLY APPROVED BY:- P. BOYLES</p>
<p>DRAWING NO. M150E25-04600</p>	<p>REV. C</p>

COPYRIGHT © 1998 - THIS DESIGN/DRAWING IS THE PROPERTY OF MONO EQUIPMENT LTD. AND MUST NOT BE REPRODUCED, COPIED, NOR ITS CONTENTS DIVULGED WITHOUT PRIOR WRITTEN PERMISSION.

IF IN ANY DOUBT - ASK

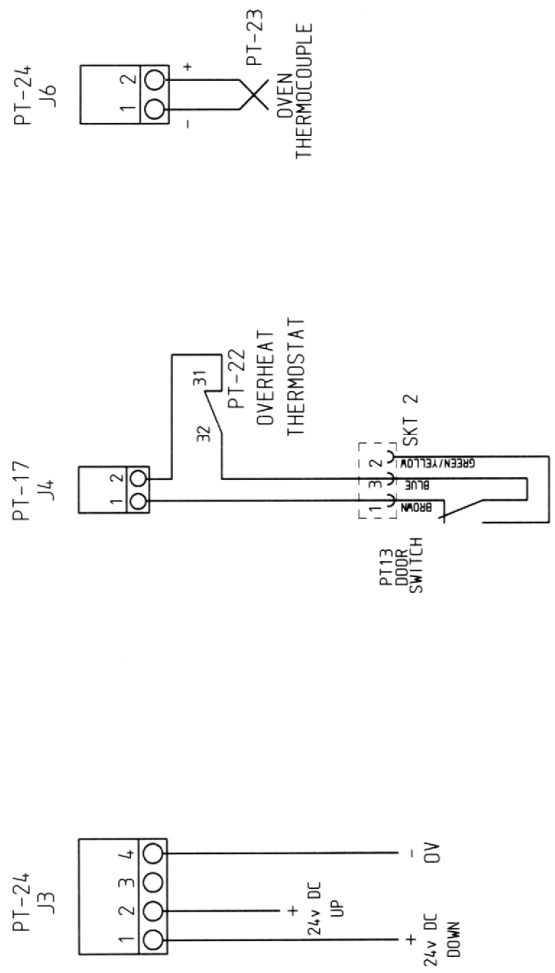

B	RAC	22-2-07	PT22 O/HEAT THERMOSTAT WIRING ALTERED	2946
A	JC	14-2-03	EXISTING SMALL FAN DELETED (IN CONJUNCTION WITH ECN 1925)	1927
REV	SIG	DATE	REVISION	ECN NO.
 MOND EQUIPMENT QUEENSWAY SWANSEA WEST IND PARK SWANSEA SA5 4EE SA5 4EE TEL: (01782) 561234 FAX: (01782) 561016			TITLE: P.C.B. INPUTS 10 TRAY CLASSIC L.E.D. OVEN	
ELECTRICAL SPECIFICATIONS:-			DRAWN: JC	ELECTRICALLY APPROVED BY: P. BOYLES
			DATE: 25-1-01	DRAWING NO. M150E25-044.00
			REV: B	

COPYRIGHT © 1998 - THIS DESIGN/DRAWING IS THE PROPERTY OF MOND EQUIPMENT LTD. AND MUST NOT BE REPRODUCED, COPIED, NOR ITS CONTENTS DIVULGED WITHOUT PRIOR WRITTEN PERMISSION.

IF IN ANY DOUBT - ASK

380/415 VOLTS
3 PHASE-N
50 HZ

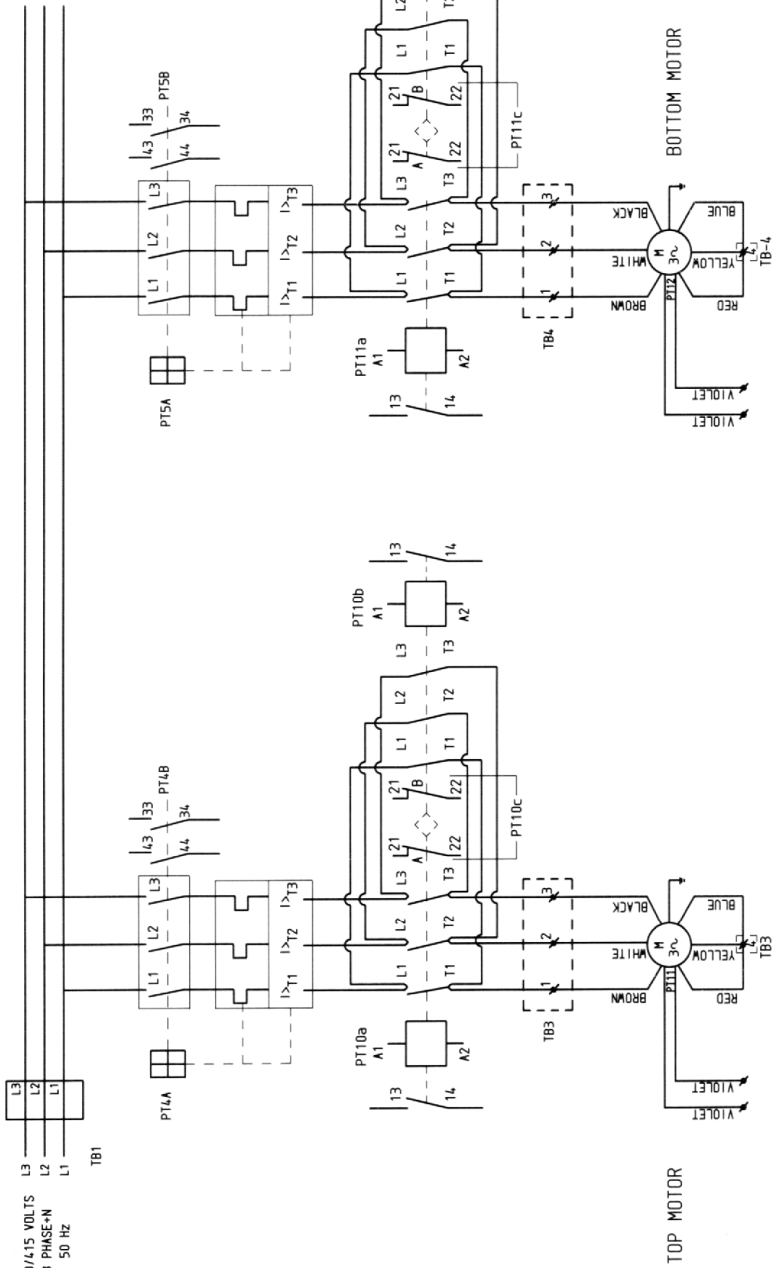

REV	SIG	DATE	REVISION	ECN NO.
<p>MOND EQUIPMENT QUEENSWAY SWANSEA WEST IND PARK SWANSEA, SA5 4RE, W. TEL: (01782) 561234 FAX: (01782) 561016</p>				
<p>ELECTRICAL SPECIFICATIONS:- 380/415V 3 PH & N 50HZ</p>			<p>TITLE: MOTOR POWER CIRCUIT DIAGRAM 10 TRAY OVEN MK11</p>	
<p>ELECTRICALLY APPROVED BY:- P. BOYLES</p>			<p>DRAWN: A.L.W.</p>	
<p>DATE: 3/2/00</p>			<p>DRAWING NO.: M150E25-03200</p>	
<p>REV: -</p>			<p>REV: -</p>	

COPYRIGHT © 1998 - THIS DESIGN/DRAWING IS THE PROPERTY OF MOND EQUIPMENT LTD. AND MUST NOT BE REPRODUCED, COPIED, NOR ITS CONTENTS DIVULGED WITHOUT PRIOR WRITTEN PERMISSION.

IF IN ANY DOUBT - ASK

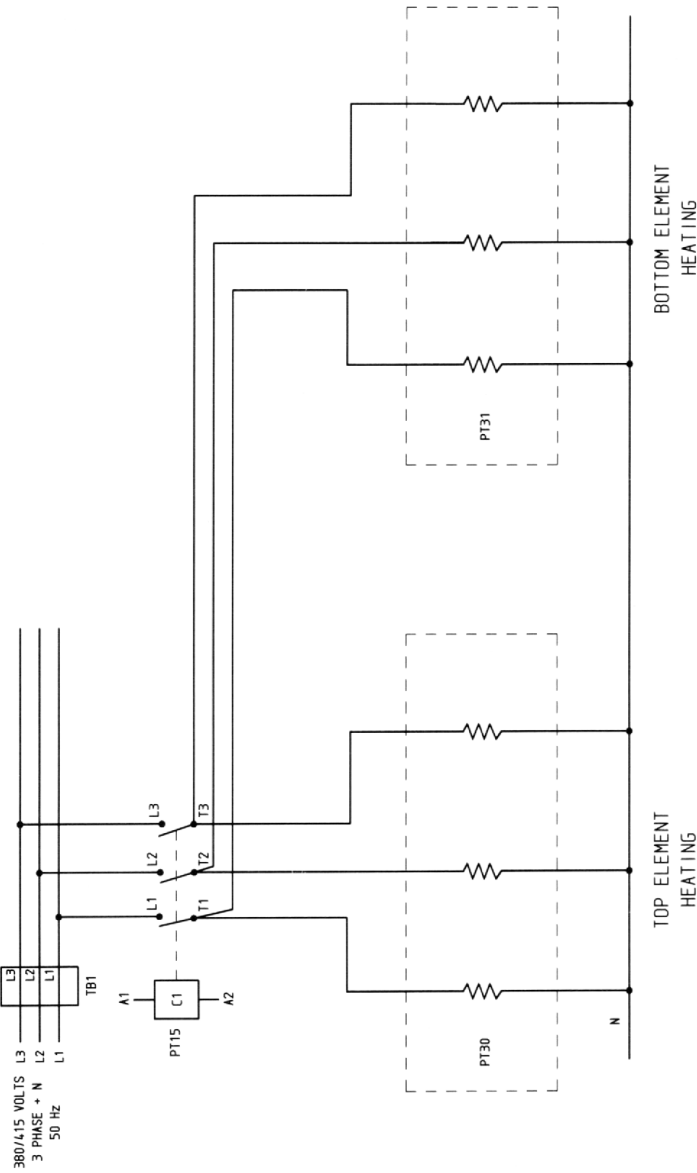

REV	SIG	DATE	REVISION	ECN NO.
A		22-2-07	PT21 & PT22 O/HEAT THERMOSTATS REMOVED	2946
		TITLE: HEATING POWER CIRCUIT DIAGRAM 10 TRAY OVEN MK11		
QUEENSWAY SWANSEA WEST IND PARK SA5 4EB SA5 4EB		DRAWN: A.L.W. DATE: 3/2/00		
TEL: (01782) 561234 FAX: (01782) 561016		ELECTRICALLY APPROVED BY: P. BOYLES		
ELECTRICAL SPECIFICATIONS:- 380/415V 3 PHASE+N 50Hz		DRAWING NO. M150E25-03300		
		REV: A		

COPYRIGHT © 1998 - THIS DESIGN/DRAWING IS THE PROPERTY OF MONO EQUIPMENT LTD. AND MUST NOT BE REPRODUCED, COPIED, NOR ITS CONTENTS DIVULGED WITHOUT PRIOR WRITTEN PERMISSION.

IF IN ANY DOUBT - ASK

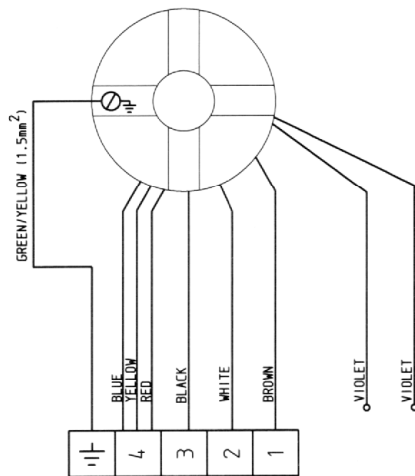

TOP MOTOR PT 18
CLOCKWISE DIRECTION WHEN
VIEWED FROM FRONT OF OVEN

- L1 1.5 mm² PTEMP
- L2 1.5 mm² PTEMP
- L3 1.5 mm² PTEMP
- N 1.5 mm² PTEMP

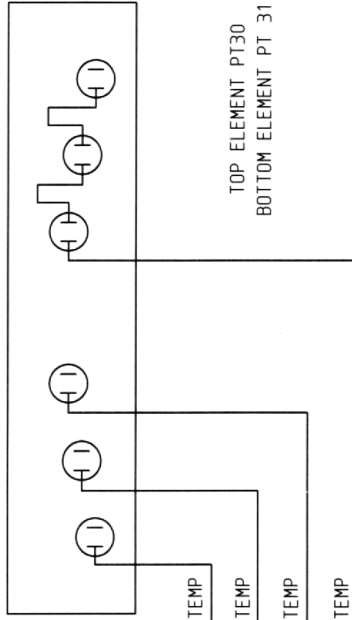

HEATING ELEMENT WIRING

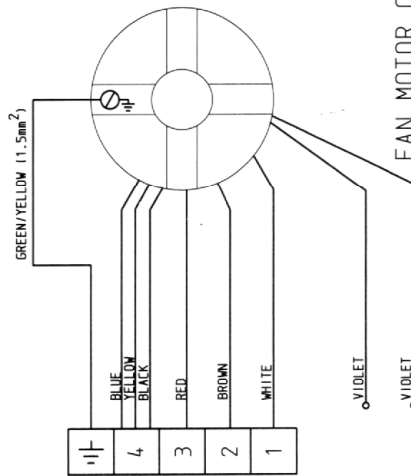

BOTTOM MOTOR PT 19
ANTI-CLOCKWISE DIRECTION WHEN
VIEWED FROM FRONT OF OVEN

FAN MOTOR CONNECTIONS

REV	SIG	DATE	REVISION	ECN NO.
			FAN MOTOR CONNECTIONS & HEATING ELEMENT WIRING 10 TRAY OVEN	
<p>MONO EQUIPMENT QUEENSWAY SWANSEA WEST IND PARK SWANSEA SA5 4EB. TEL: (01782) 561234 FAX: (01782) 561016</p>			<p>TITLE:</p>	
ELECTRICAL SPECIFICATIONS-			DRAWN: ELECTRICALLY APPROVED BY:-	
380/415V 3PH+N 50Hz			A.L.W. P. BOYLES	
			DATE: 3/2/00	
			DRAWING NO. M150E25-03400	
			REV: -	

COPYRIGHT © 1998 - THIS DESIGN/DRAWING IS THE PROPERTY OF MONO EQUIPMENT LTD. AND MUST NOT BE REPRODUCED. COPIED,
OR ITS CONTENTS DIVULGED WITHOUT PRIOR WRITTEN PERMISSION.

FG156 CLASSIC 2 TRAY

M156E25-13500	COMPONENTS
M156E25-13000	CONTROL AND POWER CIRCUIT
M156E25-13600	PCB OUTPUTS
M156-25-50500	PCB INPUTS
M156-25-50800	PCB CONNECTIONS
M156E25-50200	COMPONENTS (1 PHASE)

FOR ENGINEERS USE ONLY.
DO NOT ATTEMPT ANY ALTERATIONS.
IF IN DOUBT, CONTACT MONO FOR ADVICE

SECTION 2

IF IN ANY DOUBT - ASK

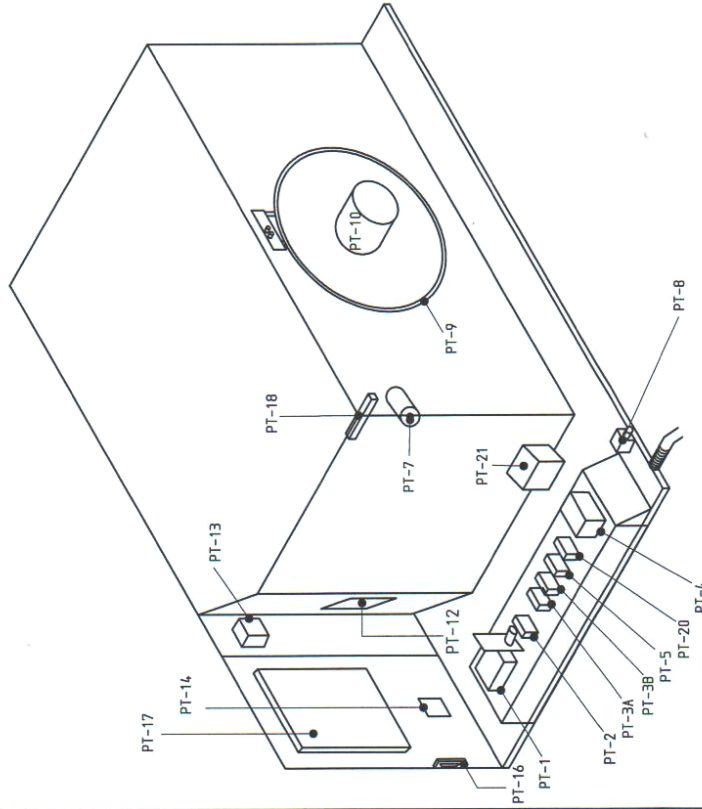

DRAWING PT-Ref	DESCRIPTION	MONO PART NUMBER
PT-1	24V DC POWER SUPPLY	B801-93-005
PT-2	INTERNAL LIGHT RELAY	B723-37-021
PT-3A	FAN MOTOR RELAY	B723-37-021
PT-3B	FAN MOTOR RELAY	B723-37-021
PT-4	HEATING ELEMENT CONTACTOR	3801-08-021
PT-5	CONTROL FUSE	B842-85-039
PT-7	DAMPER SOLENOID	B749-83-003
PT-8	2T WATER INLET ASSY	156-37-00400
* PT-9	(240V) HEATING ELEMENT	B856-04-117
PT-10	FAN MOTOR	B720-74-004
PT-12a	INTERIOR LIGHT UNIT	B721-67-011
PT-12b	INTERIOR LIGHT BULB (HAL)	B857-94-007
PT-13	DOOR SWITCH	B842-07-023
PT-14	ON/OFF SWITCH	B836-07-004
PT-16	DATA LINK SOCKET LEAD	B705-25-005
PT-17a	PCB ASSEMBLY	B705-97-013
PT-18	OVEN THERMOCOUPLE	B873-95-002
PT-20	INTERIOR LIGHT FUSE	B842-85-042
PT-21	OVERHEAT THERMOSTAT	B888-30-014
PT-23	CAPACITOR	B720-23-003

REV	SIG	DATE	REVISION	ECN NO.
<p>MONO EQUIPMENT QUEENSWAY SWANSEA WEST IND PARK SWANSEA, SAS 4EB. TEL: (01792) 561234 FAX: (01792) 561016</p>				
<p>MONO</p>			<p>TITLE: ELECTRICAL COMPONENTS LAYOUT 2 TRAY 1 PHASE CLASSIC TWO-MT FAN</p>	
<p>ELECTRICAL SPECIFICATIONS:- 220/240V 1 PHASE</p>			<p>DRAWN: ELECTRICALLY APPROVED BY:- JC/RAC</p>	
<p>DATE: 70809</p>			<p>DRAWING NO: M156E25-13500</p>	
<p>REV: --</p>			<p>REV: --</p>	

COPYRIGHT © 1998 - THIS DESIGN/DRAWING IS THE PROPERTY OF MONO EQUIPMENT LTD. AND MUST NOT BE REPRODUCED, COPIED, NOR ITS CONTENTS DIVULGED WITHOUT PRIOR WRITTEN PERMISSION.

IF IN ANY DOUBT - ASK

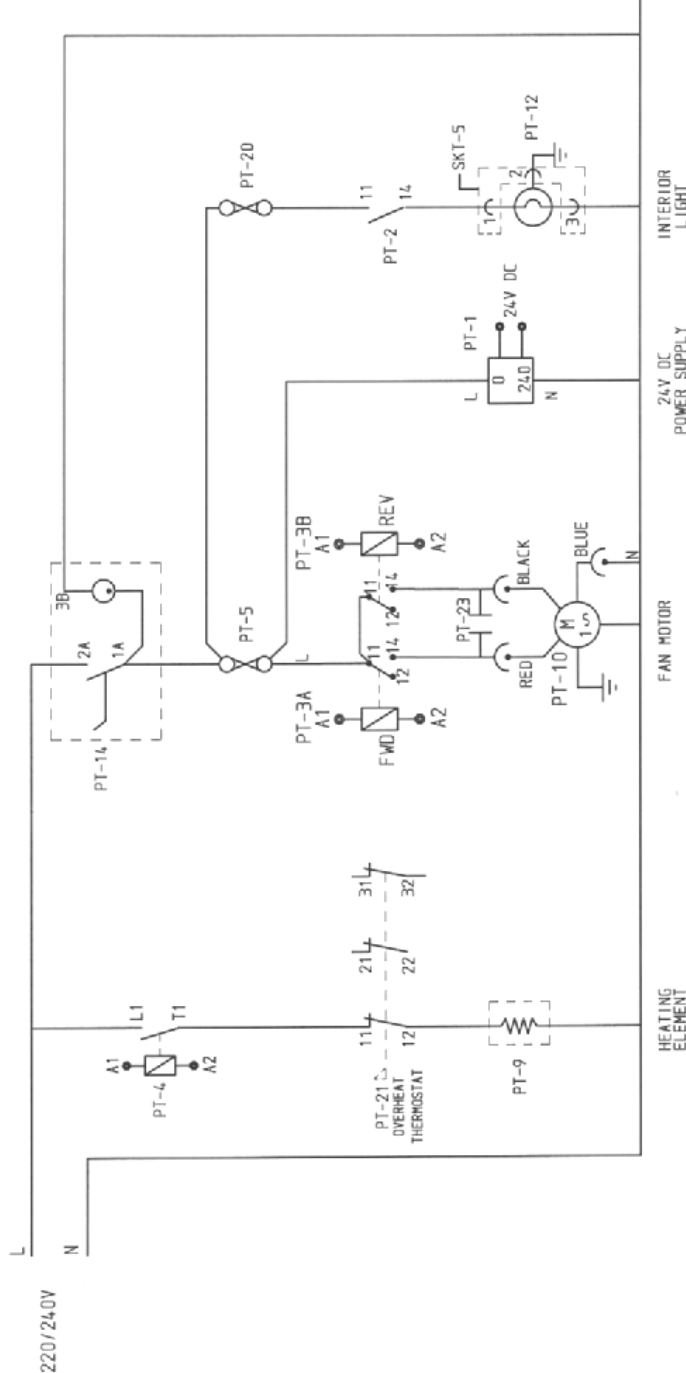

REV	SIG	DATE	REVISION	ECN NO.
MOND EQUIPMENT QUEENSWAY SWANSEA WEST IND PARK SWANSEA, SAS 4EB. TEL: (01792) 561234 FAX: (01792) 361076			TITLE: CONTROL & POWER CIRCUIT DIAGRAM FOR 220/240V 1 PHASE 2 TRAY 2 WAY FAN	
ELECTRICAL SPECIFICATIONS:- 220/240V 1 PHASE			DRAWN: RAC DATE: 28-7-09	
ELECTRICALLY APPROVED BY:- A. THOMAS			DRAWING NO. M156E25-13000	
COPYRIGHT © 1998 - THIS DESIGN/DRAWING IS THE PROPERTY OF MOND EQUIPMENT LTD. AND MUST NOT BE REPRODUCED, COPIED, NOR ITS CONTENTS DIVULGED WITHOUT PRIOR WRITTEN PERMISSION.				

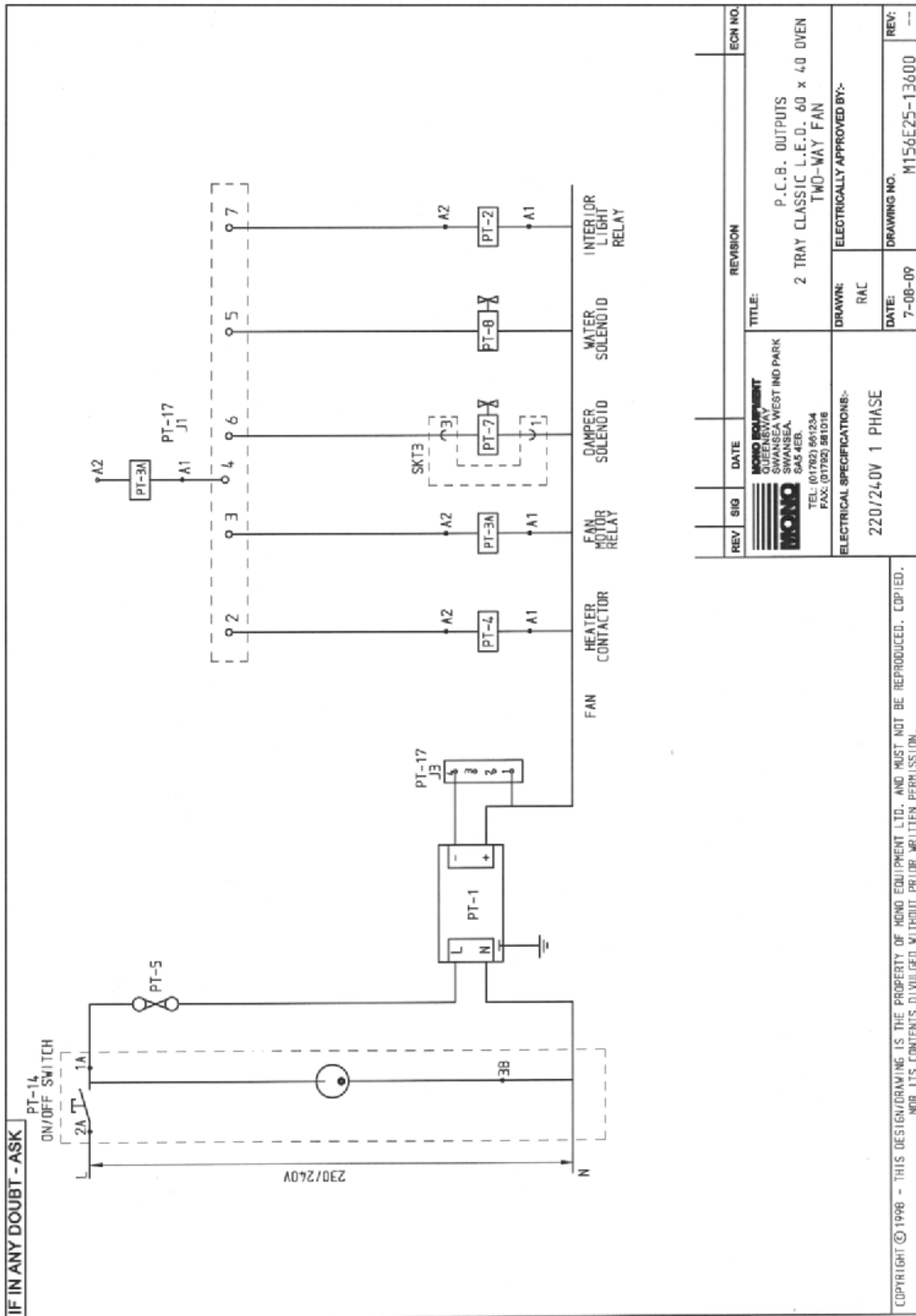

IF IN ANY DOUBT - ASK

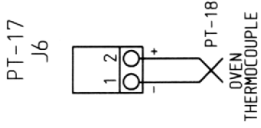
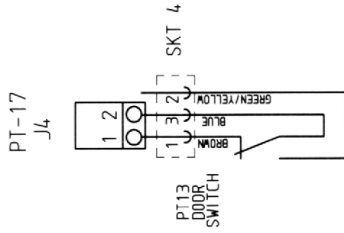

REV	SIG	DATE	REVISION	ECN NO.
		MOND EQUIPMENT QUEENSWAY SWANSEA WEST IND PARK SA5 4EB SA5 4EB TEL: (01782) 561324 FAX: (01782) 561016	TITLE: P.C.B. INPUTS 2 TRAY 'CLASSIC' L.E.D.	
ELECTRICAL SPECIFICATIONS:- 220/240V 1 PHASE 380/415 2 PHASE + N		DRAWN: MT	ELECTRICALLY APPROVED BY:- P.BOYLES	
		DATE: 14-1-99	DRAWING NO. M156-25-50500	REV: -

COPYRIGHT © 1998 - THIS DESIGN/DRAWING IS THE PROPERTY OF MOND EQUIPMENT LTD. AND MUST NOT BE REPRODUCED, COPIED, OR ITS CONTENTS DIVULGED WITHOUT PRIOR WRITTEN PERMISSION.

CONTROLLER BOARD AS VIEWED FROM COMPONENT SIDE
'CLASSIC' OVEN CONTROLLER

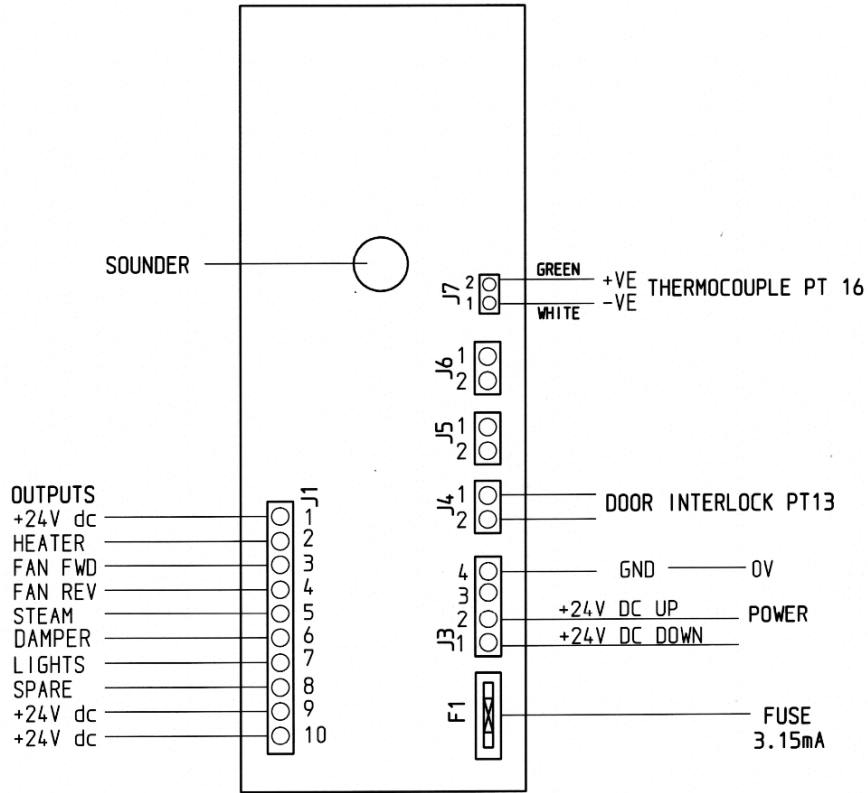

D	RAC	4-11-16	PICTORIAL CHANGES. BOARD WAS B705-97-013 NOW B705-97-027	BX-006-16-17
C	JC	24-1-03	DELETE SMALL COOLING FAN (IN CONJUNCTION WITH ECN 1927)	1925
B	JC	22-1-03	ADD WIRING FOR REAR FAN UNIT	1927
A	JC	22-2-01	RE-ARRANGE POWER CIRCUIT WIRES TO PCB	14/19

REV	SIG	DATE	REVISION	ECN NO.
-----	-----	------	----------	---------

 <p>MONO EQUIPMENT QUEENSWAY SWANSEA WEST IND PARK SWANSEA. SA5 4EB. TEL: (01792) 561234 FAX: (01792) 561016</p>	TITLE: MAIN P.C.B. CONNECTIONS 4 TRAY CLASSIC OVEN		
	DRAWN: MT	ELECTRICALLY APPROVED BY:-	
ELECTRICAL SPECIFICATIONS:-	DATE: 1-12-98	DRAWING NO. M158E25-50800	REV: D

IF IN ANY DOUBT - ASK

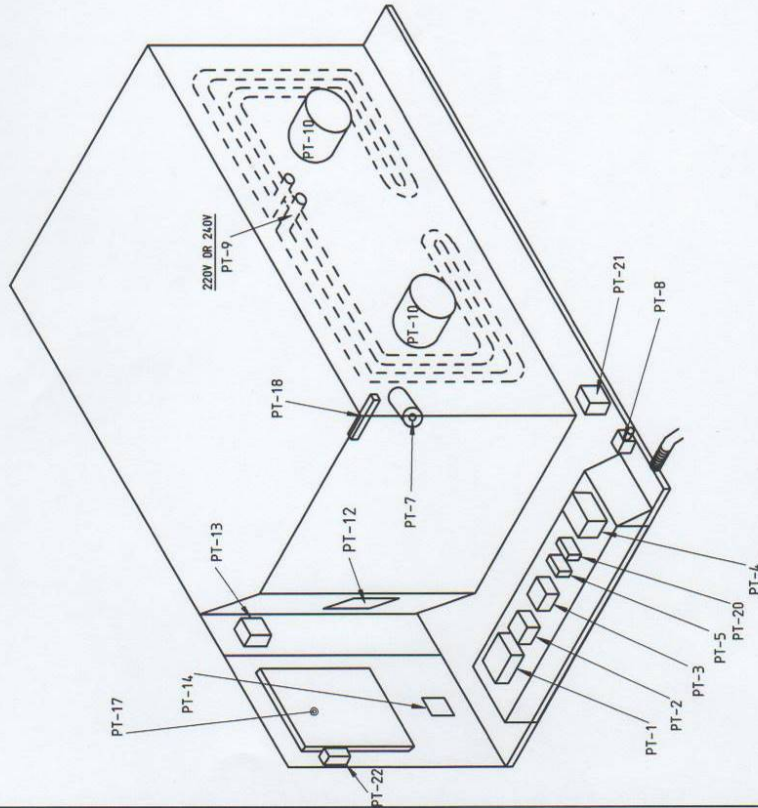

DRAWING PT-Ref	DESCRIPTION	MONO PART NUMBER
PT-1	24V DC POWER SUPPLY	B801-93-005
PT-2	INTERNAL LIGHT RELAY	B723-37-001
PT-3	FAN MOTOR RELAY	B723-37-002
PT-4	HEATING ELEMENT CONTACTOR	B801-08-021
PT-5	CONTROL FUSE	B842-85-039
PT-7	DAMPER SOLENOID	B749-83-003
PT-8	WATER INLET ASSY	156-37-00400
* PT-9	(240V) HEATING ELEMENT	B847-04-049
* PT-9	(220V) HEATING ELEMENT	B847-04-053
PT-10	FAN MOTOR	B869-75-016
PT-12a	INTERIOR LIGHT UNIT	B721-67-011
PT-12b	INTERIOR LIGHT BULB	B857-94-007
PT-13	DOOR SWITCH	B842-07-037
PT-14	ON/OFF SWITCH	B836-07-004
PT-17	MAIN L.E.D. P.C.B.	B705-97-013
PT-18	OVEN THERMOCOUPLE	B873-95-002
PT-20	INTERIOR LIGHT FUSE	B842-85-042
PT-21	OVERHEAT THERMOSTAT	B888-30-014
PT-22	FAN	B842-75-002

REV	SIG	DATE	REVISION	ECH NO.
K	JC	02-05-19	PT-13 WAS B842-07-023	BX-007-18-19
J	RAC	29-03-10	PT-12A WAS B721-67-011, PT-12B WAS B857-94-007	315/09
I	JC	29-01-09	PT13 WAS ASSY 154-25-01200 (B801-11-001)	195/08
H	JC	30-10-06	PT-7 WAS B749-83-001	2868
G	RAC	20-10-05	Contractors B801 was B859	2573
F	JC	27-7-05	PT-18 WAS B873-95-001	2525
E	JC	11-7-05	PT-8 WAS B894-83-006	2507
D	JC	13-6-05	PT-1a WAS B705-93-006	2483
C	JC	7-4-05	PT-12A WAS B721-67-001	2435
B	JC	22-11-04	PT-14 WAS B842-07-014	2329
A	JC	3-3-99	PT-21 WAS B888-30-013	08/22

<p>MONO EQUIPMENT QUEENSWAY SWANSEA WEST IND PARK SWANSEA, SAS 4EB. TEL: (01782) 561234 FAX: (01782) 561016</p>		<p>TITLE: ELECTRICAL COMPONENTS LAYOUT 2 TRAY 1 PHASE 'CLASSIC'</p>
<p>ELECTRICAL SPECIFICATIONS:- 220/240V 1 PHASE</p>		<p>DRAWN: MT</p>
<p>DATE: 14-1-99</p>		<p>REVISION APPROVED BY:-</p>
<p>DRAWING NO: MT56E25-50200</p>		<p>REV: K</p>

COPYRIGHT © 1998 - THIS DESIGN/DRAWING IS THE PROPERTY OF MONO EQUIPMENT LTD. AND MUST NOT BE REPRODUCED, COPIED, NOR ITS CONTENTS DIVULGED WITHOUT PRIOR WRITTEN PERMISSION.

FG153/158/159 CLASSIC 4 TRAY 3 PHASE

M159E25-11300	COMPONENTS (159 ONLY)
M158E25-52000	COMPONENTS (153/158 ONLY)
M158E25-50800	PCB CONNECTIONS
M158E25-50500	PCB INPUTS
M158E25-50100	PCB OUTPUTS
M158E25-20700	CONTROL CIRCUIT
M158E25-01800	POWER CIRCUIT
M158E25-01900	FAN CONNECTIONS AND ELEMENT WIRING

SECTION 3

**FOR ENGINEERS USE ONLY.
DO NOT ATTEMPT ANY ALTERATIONS.
IF IN DOUBT, CONTACT MONO FOR ADVICE**

IF IN ANY DOUBT - ASK

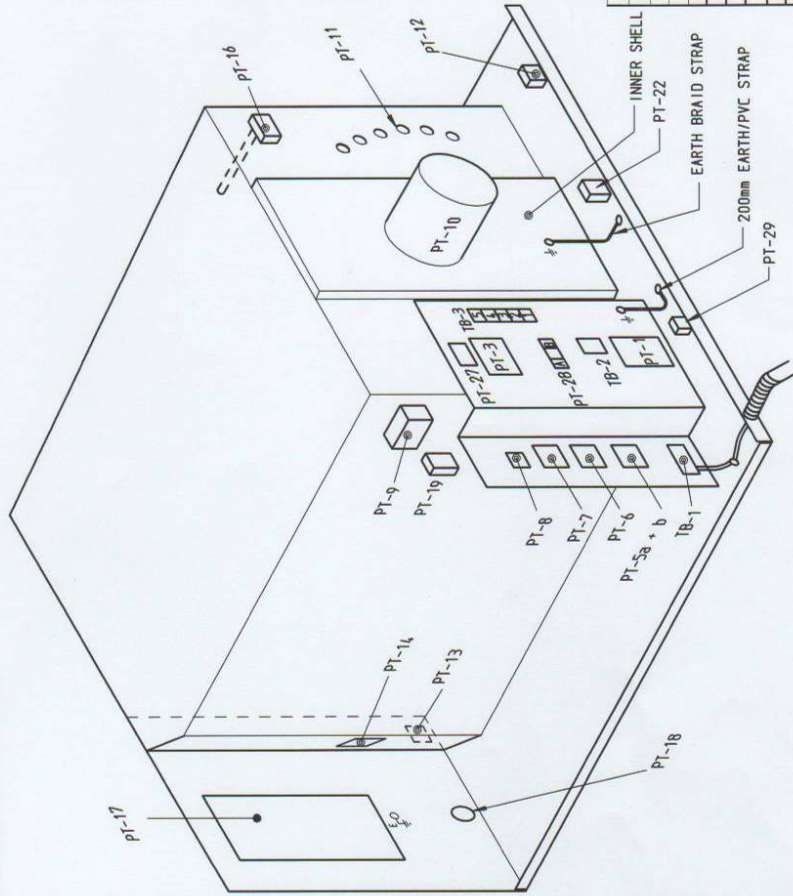

DRAWING PT-Ref	DESCRIPTION	MONO PART NUMBER
PT-1	24V DC POWER SUPPLY UNIT	B801-93-002
PT-3	CONTROL CIRCUIT M.C.B.	B872-22-062
PT-5a	FAN MOTOR OVERLOAD UNIT	B801-03-023
PT-5b	FAN MOTOR OVERLOAD AUXILIARY CONTACT	B801-11-012
PT-6	FAN MOTOR FORWARD CONTACTOR	B801-08-031
PT-7	FAN MOTOR REVERSE CONTACTOR	B801-08-031
PT-8	HEATING ELEMENT CONTACTOR	B801-08-021
PT-9	DAMPER SOLENOID (L/H)	B749-83-003
PT-10	DAMPER SOLENOID (R/H)	B749-83-004
PT-11	FAN MOTOR UNIT	B720-74-005
PT-12	HEATING ELEMENT (240v)	B847-04-068
PT-13	4T WATER INLET ASSY	156-17-004.00
PT-14	DOOR SWITCH	B842-07-037
PT-16	INTERIOR LIGHT BULB	B855-94-009
PT-17	THERMOCOUPLE	B873-95-002
PT-18	MAIN P.C.B.	B705-97-013
PT-19	MAIN ON/OFF SWITCH	B836-07-004
PT-20	REAR COOLING FAN	B869-75-018
PT-22	OVERHEAT THERMOSTAT	B888-30-014
PT-27	FAN FUSE	B842-65-025
PT-28	AUX FUSE	B842-65-039
PT-29	AUX SUPPLY SOCKET	B970-06-001

REV	SIG	DATE	REVISION	EON NO.
L	JC	02-05-19	PT-13 WAS B842-07-023	BX-001-18-19
K	JC	27-11-18	PT-10 WAS B720-74-001	BX-009-17-18
J	RAC	11-11-09	PT2_25_14A DELETED PT14B WAS B857-94-004	195/08
H	JC	29-01-09	PT13 WAS ASSY 154-25-01200 (B801-11-001)	195/08
G	JC	27-03-07	PT28 & 29 ADDED	2946
F	JC	30-10-06	PT-9 WAS B749-83-001 & B749-83-002	2868
E	JC	7-11-05	B801 WAS B859	2573
D	JC	3-8-05	PT-12 WAS B994-83-003	2528
C	JC	27-7-05	PT-16 WAS B873-95-001	2525
B	JC	13-6-05	PT-1 WAS B705-93-006	2483
A	JC	7-4-05	PT-14A WAS B721-67-001	2435

		MONO EQUIPMENT QUEENSWAY SWANSEA WEST IND PARK SWANSEA, S.W. WALES SA6 4EB. TEL: (01792) 661234 FAX: (01792) 561016	
TITLE: ELECTRICAL COMPONENTS LAYOUT 4 TRAY 30 X 18 CLASSIC WITH FORWARD & REVERSE FANS		DRAWN: JC	
ELECTRICAL SPECIFICATIONS:- 380/4.15v 3PH 50Hz		DATE: 24-02-05	
REVISION		DATE: 24-02-05	
DATE: 24-02-05		DRAWING NO.: M159E25-11300	
REV: L		REV: L	

COPYRIGHT © 1998 - THIS DESIGN/DRAWING IS THE PROPERTY OF MONO EQUIPMENT LTD. AND MUST NOT BE REPRODUCED, COPIED, NOR ITS CONTENTS DIVULGED WITHOUT PRIOR WRITTEN PERMISSION.

IF IN ANY DOUBT - ASK

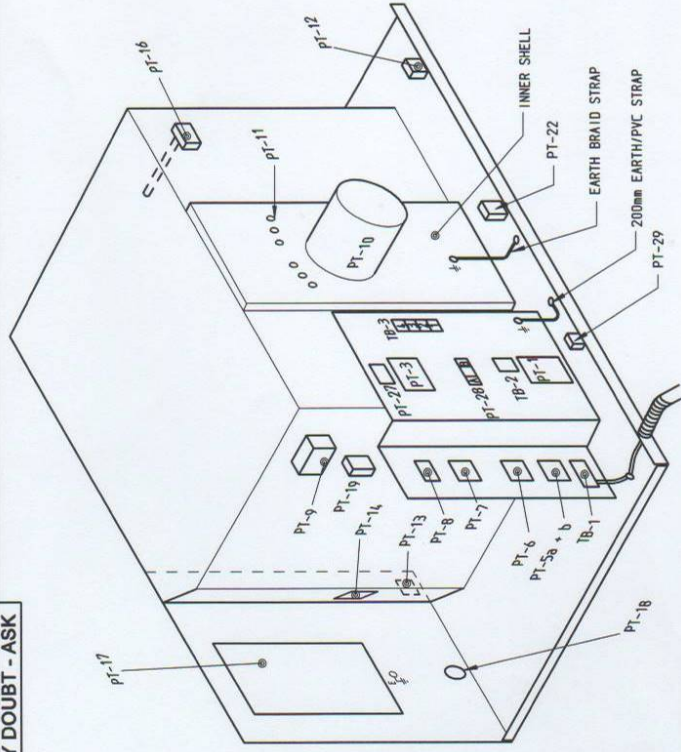

DRAWING PT-Ref	DESCRIPTION	MONO PART NUMBER
PT-1	24V DC POWER SUPPLY UNIT	8801-93-005
PT-3	CONTROL CIRCUIT M.C.B.	8872-22-062
PT-5a	FAN MOTOR OVERLOAD UNIT	8801-03-023
PT-5b	FAN MOTOR OVERLOAD AUXILIARY CONTACT	8801-14-012
PT-6	FAN MOTOR FORWARD CONTACTOR	8801-08-031
PT-7	FAN MOTOR REVERSE CONTACTOR	8801-08-031
PT-8	HEATING ELEMENT CONTACTOR	8801-08-021
PT-9	DAMPER SOLENOID (L/H)	8749-83-003
PT-10	DAMPER SOLENOID (R/H)	8749-83-004
PT-11	FAN MOTOR UNIT	8720-74-005
PT-11	HEATING ELEMENT (240v)	8847-04-067
PT-11	HEATING ELEMENT (220v)	8847-04-074
PT-12	4T WATER INLET ASSY	158-17-00400
PT-13	DOOR SWITCH	8842-07-037
PT-14B	INTERIOR LIGHT BULB	8859-94-009
PT-16	THERMOCOUPLE	8873-95-002
PT-17	MAIN P.C.B.	8705-97-013
PT-18	MAIN ON/OFF SWITCH	8836-07-004
PT-19	REAR COOLING FAN	8869-75-018
PT-22	OVERHEAT THERMOSTAT	8888-30-014
PT-27	FAN FUSE	8842-85-025
PT-28	AUX FUSE	8842-85-039
PT-29	AUX SUPPLY SOCKET	8970-06-001

REV	SIG	DATE	REVISION	ECN NO.
BX-001-18-19				
BX-009-17-18				
315/09				
195/08				
294/6				
2868				
2573				
2528				
2525				
2483				
2435				
2329				
2318				
1925				
1927				

DRAWING PT-Ref	DESCRIPTION	MONO PART NUMBER
PT-1	24V DC POWER SUPPLY UNIT	8801-93-005
PT-3	CONTROL CIRCUIT M.C.B.	8872-22-062
PT-5a	FAN MOTOR OVERLOAD UNIT	8801-03-023
PT-5b	FAN MOTOR OVERLOAD AUXILIARY CONTACT	8801-14-012
PT-6	FAN MOTOR FORWARD CONTACTOR	8801-08-031
PT-7	FAN MOTOR REVERSE CONTACTOR	8801-08-031
PT-8	HEATING ELEMENT CONTACTOR	8801-08-021
PT-9	DAMPER SOLENOID (L/H)	8749-83-003
PT-10	DAMPER SOLENOID (R/H)	8749-83-004
PT-11	FAN MOTOR UNIT	8720-74-005
PT-11	HEATING ELEMENT (240v)	8847-04-067
PT-11	HEATING ELEMENT (220v)	8847-04-074
PT-12	4T WATER INLET ASSY	158-17-00400
PT-13	DOOR SWITCH	8842-07-037
PT-14B	INTERIOR LIGHT BULB	8859-94-009
PT-16	THERMOCOUPLE	8873-95-002
PT-17	MAIN P.C.B.	8705-97-013
PT-18	MAIN ON/OFF SWITCH	8836-07-004
PT-19	REAR COOLING FAN	8869-75-018
PT-22	OVERHEAT THERMOSTAT	8888-30-014
PT-27	FAN FUSE	8842-85-025
PT-28	AUX FUSE	8842-85-039
PT-29	AUX SUPPLY SOCKET	8970-06-001

REV	SIG	DATE	REVISION	ECN NO.
BX-001-18-19				
BX-009-17-18				
315/09				
195/08				
294/6				
2868				
2573				
2528				
2525				
2483				
2435				
2329				
2318				
1925				
1927				

REV	SIG	DATE	REVISION	ECN NO.
BX-001-18-19				
BX-009-17-18				
315/09				
195/08				
294/6				
2868				
2573				
2528				
2525				
2483				
2435				
2329				
2318				
1925				
1927				

CONTROLLER BOARD AS VIEWED FROM COMPONENT SIDE
 MONO 'CLASSIC' OVEN CONTROLLER

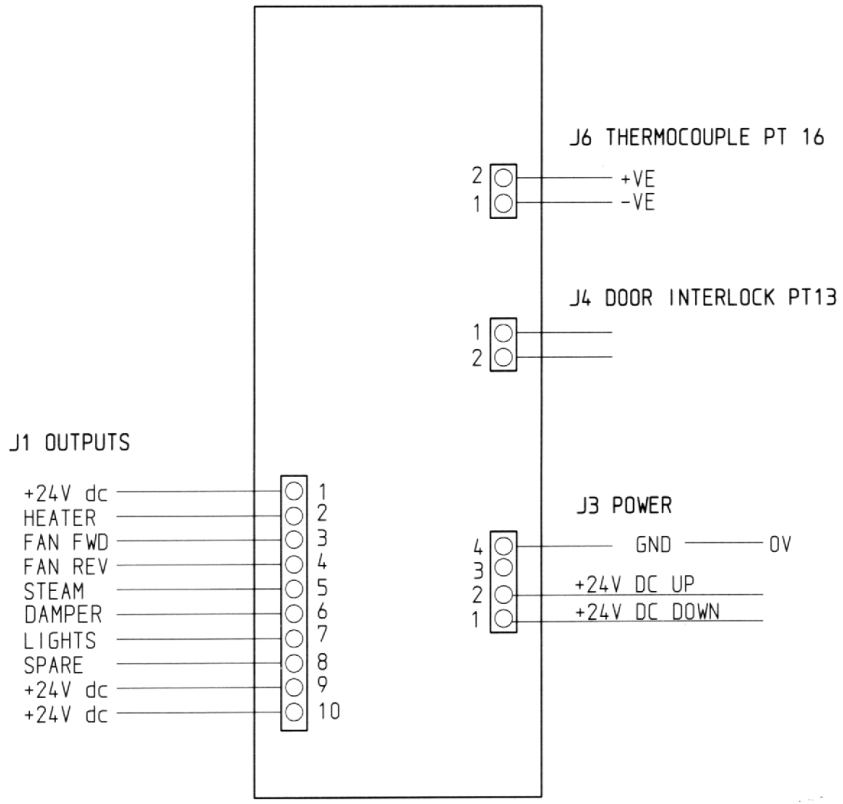

C	JC	24-1-03	DELETE SMALL COOLING FAN (IN CONJUNCTION WITH ECN 1927)	1925
B	JC	22-1-03	ADD WIRING FOR REAR FAN UNIT	1927
A	JC	22-2-01	RE-ARRANGE POWER CIRCUIT WIRES TO PCB	14/19

REV	SIG	DATE	REVISION	ECN NO.
		MONO EQUIPMENT QUEENSWAY SWANSEA WEST IND PARK SWANSEA. SA5 4EB. TEL: (01792) 561234 FAX: (01792) 561016		TITLE: MAIN P.C.B. CONNECTIONS 4 TRAY CLASSIC OVEN
ELECTRICAL SPECIFICATIONS:-		DRAWN: MT	ELECTRICALLY APPROVED BY:- P. BOYLES	
		DATE: 1-12-98	DRAWING NO. M158E25-50800	REV: C

IF IN ANY DOUBT - ASK

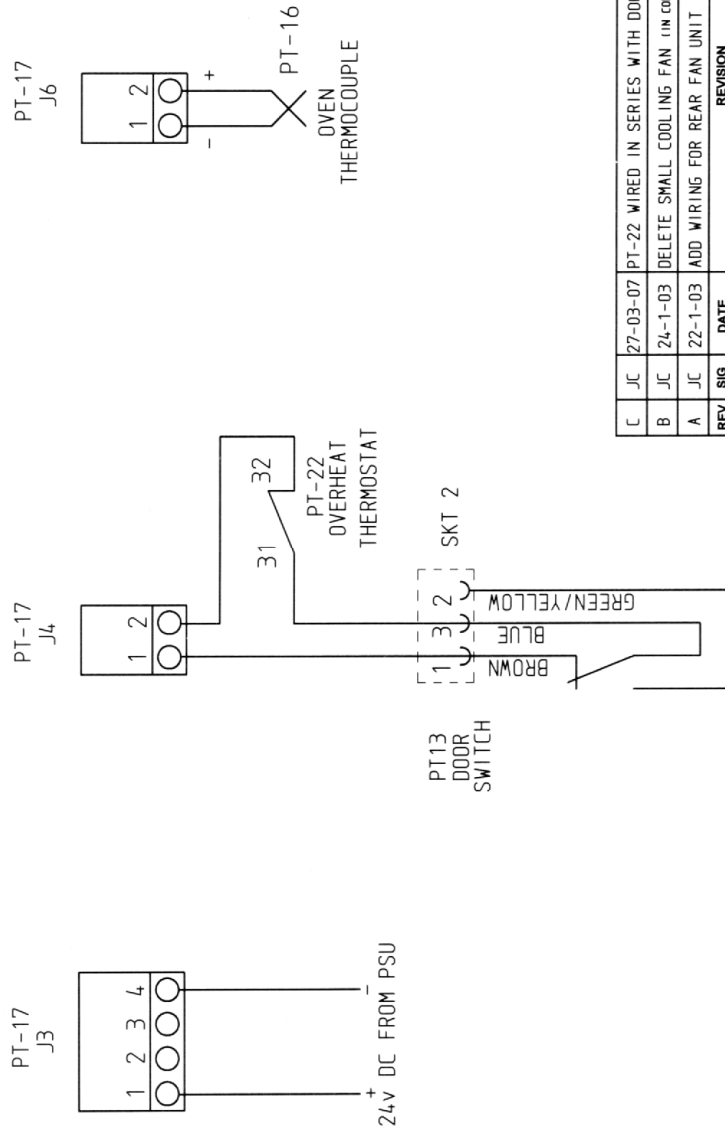

C	JC	27-03-07	PT-22 WIRED IN SERIES WITH DOOR SWITCH(PT-13)	2946
B	JC	24-1-03	DELETE SMALL COOLING FAN (IN CONJUNCTION WITH ECM 1927)	1925
A	JC	22-1-03	ADD WIRING FOR REAR FAN UNIT	1927
REV	SIG	DATE	REVISION	ECN NO.
 MOND EQUIPMENT QUEENSWAY SWANSEA WEST IND PARK SWANSEA SA5 4EEA TEL: (01792) 561234 FAX: (01792) 561016			TITLE: P.C.B. INPUTS 4 TRAY CLASSIC OVEN	
ELECTRICAL SPECIFICATIONS:-			DRAWN: MT	ELECTRICALLY APPROVED BY: P. BOYLES
			DATE: 26-11-98	DRAWING NO. M158E25-50500
			REV: C	

COPYRIGHT © 1998 - THIS DESIGN/DRAWING IS THE PROPERTY OF MOND EQUIPMENT LTD. AND MUST NOT BE REPRODUCED, COPIED, NOR ITS CONTENTS DIVULGED WITHOUT PRIOR WRITTEN PERMISSION.

IF IN ANY DOUBT - ASK

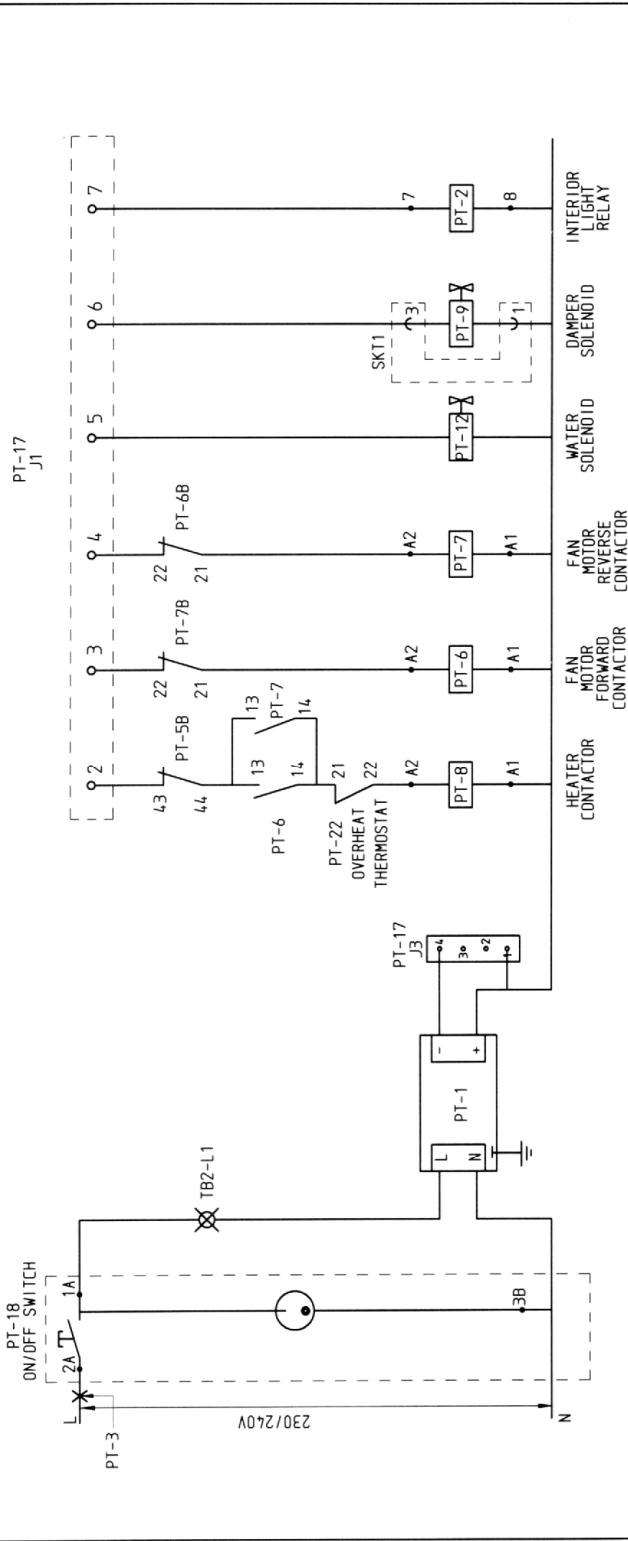

REV	SIG	DATE	REVISION	ECN NO.
F	JC	27-03-07	PT-22 WIRING CHANGED	2946
E	JC	7-11-05	A1 AND A2 CHANGED AROUND	2573
D	JC	22-11-04	PT-1B WAS B869-75-023	2318
C	JC	26-9-03	PT18 WIRED IN CONJUNCTION WITH ECN 2055-2057	2058
B	JC	24-1-03	DELETE SMALL COOLING FAN (IN CONJUNCTION WITH ECN 1927)	1925
A	JC	22-1-03	ADD WIRING FOR REAR FAN UNIT	1927

MONO EQUIPMENT
 QUEENSWAY
 SWANSEA WEST IND PARK
 SWANSEA, SA5 4EE
 TEL: (01782) 561234
 FAX: (01782) 561016

ELECTRICAL SPECIFICATIONS:-
 380/415V 3 PHASE 50HZ

TITLE:
 P.C.B. OUTPUTS
 4 TRAY CLASSIC L.E.D. OWEN

DRAWN: ELECTRICALLY APPROVED BY:
 MT P. BOYLES

DATE: 26-11-98
DRAWING NO.: M158E25-50100

REV: F

COPYRIGHT © 1998 - THIS DESIGN/DRAWING IS THE PROPERTY OF MONO EQUIPMENT LTD. AND MUST NOT BE REPRODUCED, COPIED, NOR ITS CONTENTS DIVULGED WITHOUT PRIOR WRITTEN PERMISSION.

IF IN ANY DOUBT - ASK

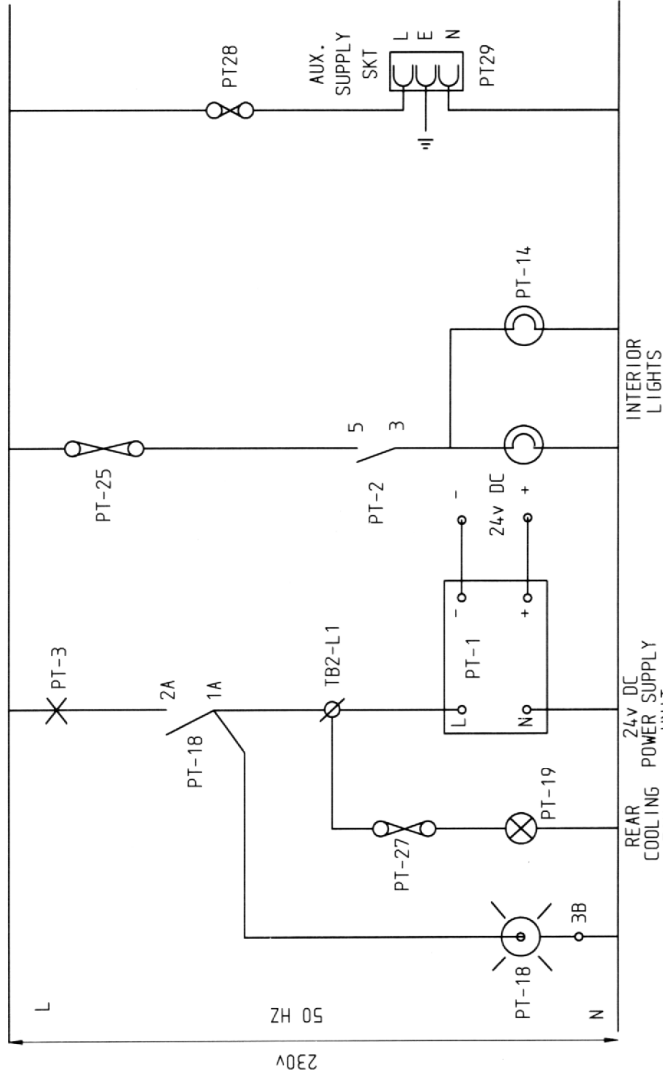

REV	SIG	DATE	REVISION	ECN NO.
D	JC	27-03-07	PT-28 & 29 ADDED	2946
C	JC	22-11-04	PT-18 CHANGED	2329
B	JC	25-9-03	SWITCH (PT-18) CHANGED	2057
A	JC	22-1-03	ADD WIRING FOR REAR FAN UNIT	1927

<p>MONO EQUIPMENT QUEENSWAY SWANSEA WEST IND PARK SWANSEA SOMERSET TEL: (01782) 561234 FAX: (01782) 561018</p>		<p>TITLE: BX 4 TRAY OWEN CONTROL CIRCUIT</p>	
ELECTRICAL SPECIFICATIONS:-		DRAWN: JC	ELECTRICALLY APPROVED BY: P. BOYLES
		DATE: 14/12/01	DRAWING NO. M158E25-20700
		REV: D	

COPYRIGHT © 1998 - THIS DESIGN/DRAWING IS THE PROPERTY OF MONO EQUIPMENT LTD. AND MUST NOT BE REPRODUCED, COPIED, NOR ITS CONTENTS DIVULGED WITHOUT PRIOR WRITTEN PERMISSION.

IF IN ANY DOUBT - ASK

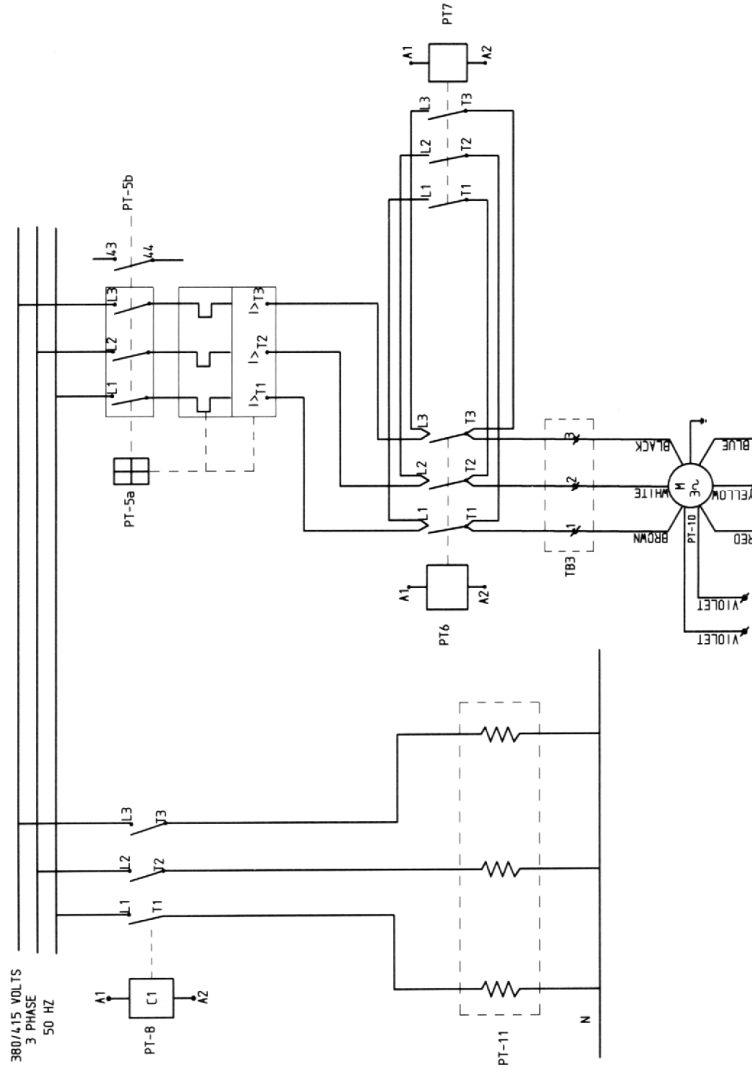

REV	SIG	DATE	REVISION	ECN NO.
A	JC	27-03-07	PT-22 REMOVED	2946

 MONO EQUIPMENT QUEENSWAY SWANSEA WEST IND PARK SWANSEA, S.A.S. 6601 TEL: (01782) 861034 FAX: (01782) 861016	TITLE:
	POWER CIRCUIT DIAGRAM 4 TRAY OVEN

ELECTRICAL SPECIFICATIONS:-	DRAWN: MT	ELECTRICALLY APPROVED BY:- P. BOTYLES
	DATE: 29-6-99	
	DRAWING NO. M158E25-01800	REV: A

COPYRIGHT © 1998 - THIS DESIGN/DRAWING IS THE PROPERTY OF MONO EQUIPMENT LTD. AND MUST NOT BE REPRODUCED, COPIED, NOR ITS CONTENTS DIVULGED WITHOUT PRIOR WRITTEN PERMISSION.

IF IN ANY DOUBT - ASK

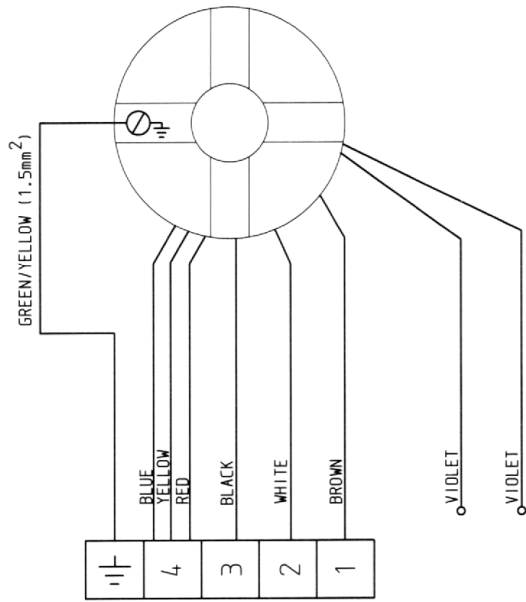

FAN MOTOR CONNECTIONS

PT11

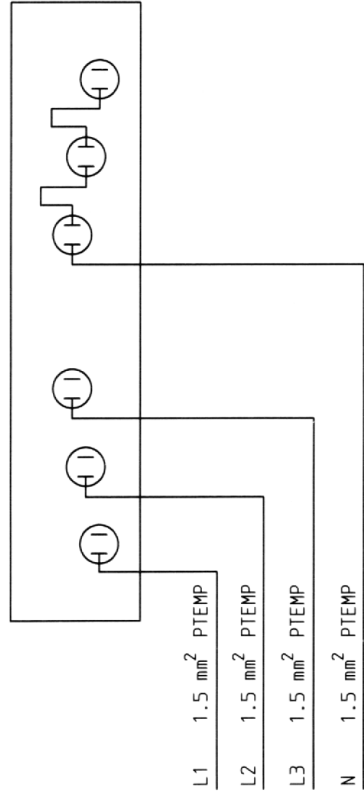

HEATING ELEMENT WIRING

REV	SIG	DATE	REVISION	ECN NO.
			FAN MOTOR CONNECTIONS & HEATING ELEMENT WIRING (RING ELEMENT TYPE)	
 MONO EQUIPMENT QUEENSWAY SWANSEA WEST IND PARK SWANSEA, WA 6106 TEL: (01792) 561234 FAX: (01792) 561016			DRAWN: MT DATE: 29-6-99 ELECTRICALLY APPROVED BY: P. BOYLES	
ELECTRICAL SPECIFICATIONS:-			DRAWING NO. M158-25-01900	
380/415V 3PH 50HZ			REV: -	

COPYRIGHT © 1998 - THIS DESIGN/DRAWING IS THE PROPERTY OF MONO EQUIPMENT LTD. AND MUST NOT BE REPRODUCED - COP'IED, NOR ITS CONTENTS DIVULGED WITHOUT PRIOR WRITTEN PERMISSION.

FG153/158/159 CLASSIC 4 TRAY 1 PHASE

M158E25-51200	COMPONENTS (153/158 ONLY)
M159E25-11200	COMPONENTS (159 ONLY)
M158E25-51400	PCB OUTPUTS
M158-25-51500	PCB CONNECTIONS
M158E25-50500	PCB INPUTS
M158E25-20700	CONTROL CIRCUIT
M158E25-51300	POWER CIRCUIT
M158E25-52200	FAN CONNECTIONS AND ELEMENT WIRING

SECTION 4

**FOR ENGINEERS USE ONLY.
DO NOT ATTEMPT ANY ALTERATIONS.
IF IN DOUBT, CONTACT MONO FOR ADVICE**

IF IN ANY DOUBT - ASK

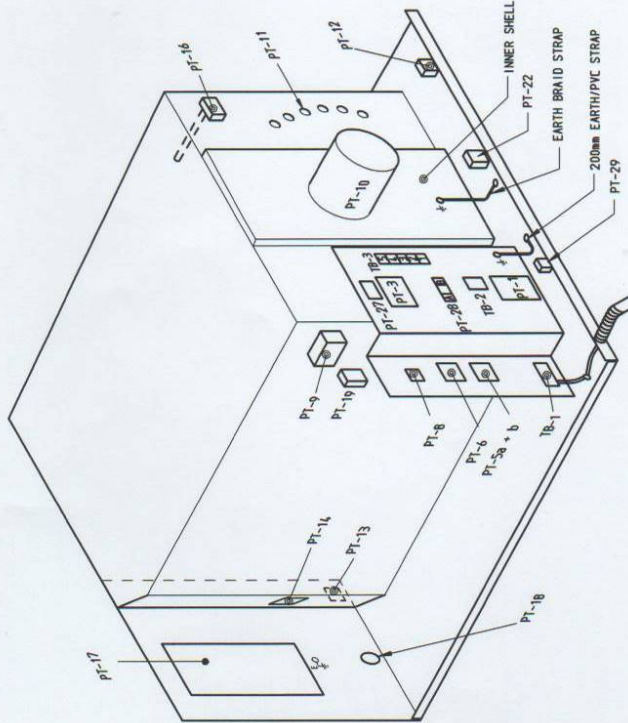

DRAWING PT-Ref	DESCRIPTION	MONO PART NUMBER
PT-1	24V DC POWER SUPPLY UNIT	BB01-93-005
PT-3	CONTROL CIRCUIT M.C.B.	BB72-22-042
PT-5a	FAN MOTOR OVERLOAD UNIT	BB01-03-023
PT-5b	FAN MOTOR OVERLOAD AUXILIARY CONTACT	BB01-14-012
PT-6	FAN MOTOR FORWARD CONTACTOR	BB01-08-031
PT-8	HEATING ELEMENT CONTACTOR	BB01-08-021
PT-9	DAMPER SOLENOID (L/H)	B749-83-003
PT-10	FAN MOTOR UNIT	B720-74-005
PT-11	HEATING ELEMENT	BB47-04-068
PT-12	4T WATER INLET ASSY	158-17-00400
PT-13	DOOR SWITCH	BB42-07-037
PT-14b	INTERIOR LIGHT BULB	BB55-94-009
PT-16	THERMOCOUPLE	BB73-95-002
PT-17	MAIN P.C.B.	BB05-97-013
PT-18	MAIN ON/OFF SWITCH	BB34-07-004
PT-19	REAR COOLING FAN	BB89-75-018
PT-22	OVERHEAT THERMOSTAT	BB88-30-014
PT-26	FAN MOTOR CAPACITOR	B720-23-001
PT-27	FAN FUSE	BB42-85-025
PT-28	AUX FUSE	BB42-85-039
PT-29	AUX SUPPLY SOCKET	BB70-06-001

REV	SIG	DATE	REVISION	ECN NO.
L	JC	02-05-19	PT-13 WAS B842-07-023	BX-001-18-19
K	JC	27-11-18	PT-10 WAS B720-74-001	BX-009-17-18
J	RAC	18-11-09	PT2, 14A, 25 DELETED. PT14B WAS B857-94-004	315709
H	JC	29-01-09	PT13 WAS ASSY 154-25-01200 (B801-11-001)	195708
G	JC	27-03-07	PT-28 & 29 ADDED	2946
F	JC	30-10-06	PT-9 WAS B749-83-001 & B749-83-002	2868
E	RAC	1-11-05	B801- was B859-	2573
D	JC	3-8-05	PT-12 WAS B994-83-003	2528
C	JC	27-7-05	PT-16 WAS B873-95-001	2525
B	JC	13-6-05	PT-1 WAS B705-93-006	2483
A	JC	7-4-05	PT-14A WAS B721-67-001	2435
REV. SIG. DATE REVISION COPYRIGHT © 1998 - THIS DESIGN/DRAWING IS THE PROPERTY OF MONO EQUIPMENT LTD. AND MUST NOT BE REPRODUCED, COPIED, NOR ITS CONTENTS DIVULGED WITHOUT PRIOR WRITTEN PERMISSION.				ECN NO.

<p>MONO EQUIPMENT QUEENSWAY SWANSEA WEST IND PARK SWANSEA, SAS GEB. TEL: (01782) 661234 FAX: (01782) 561016</p>	<p>DATE: 06-12-04</p> <p>DRAWING NO: M159E25-11200</p> <p>REV: L</p>
<p>REVISION</p> <p>TITLE: ELECTRICAL COMPONENTS LAYOUT 4 TRAY 30 X 18 CLASSIC, ONE WAY FAN ROTATING OVEN WITH STANDARD FAN IMPELLER</p>	<p>ECN NO.</p>
<p>ELECTRICAL SPECIFICATIONS:-</p> <p>230V 1PH 50HZ</p>	<p>DRAWN: JC</p> <p>ELECTRICALLY APPROVED BY:-</p>

IF IN ANY DOUBT - ASK

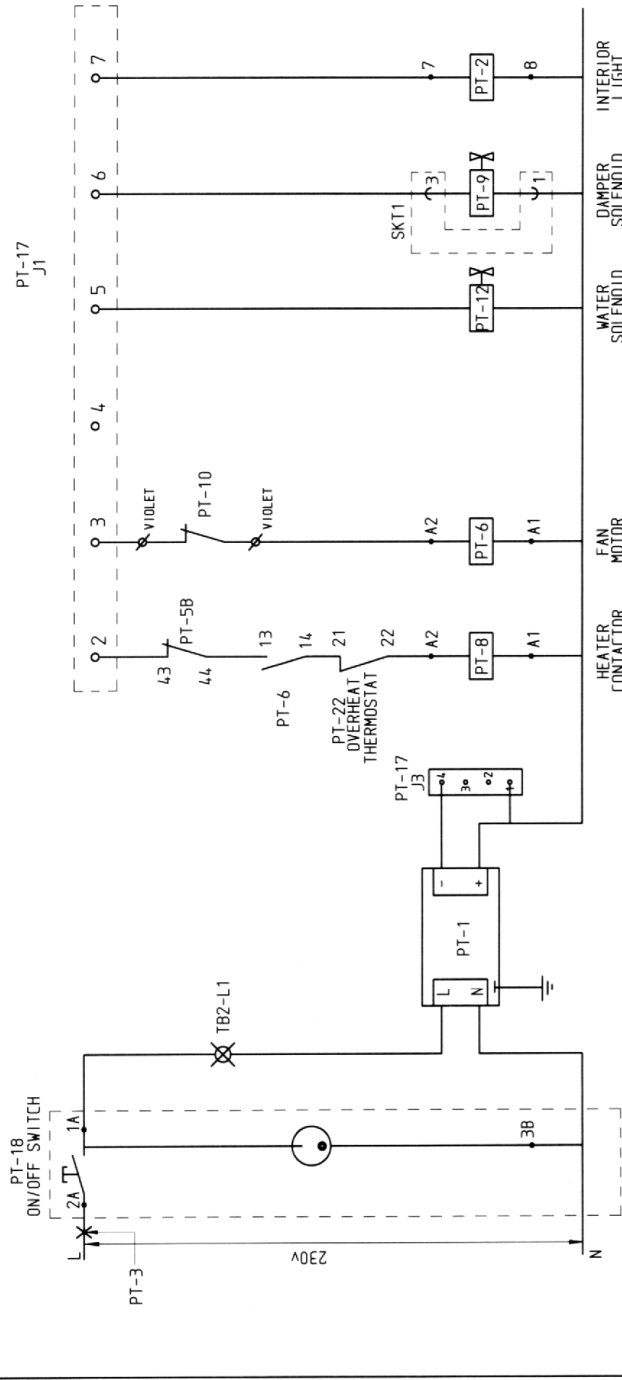



REV	SIG	DATE	REVISION	ECN NO.
F	JC	27-03-07	PT-22 WIRING CHANGED	2946
E	RAC	1-11-05	A1 A2 reversed	2573
D	JC	22-11-04	PT-18 WAS B642-07-014	2329
C	JC	26-9-03	PT18 WIRED IN CONJUNCTION WITH ECN 2055-2057	2058
	JC	24-1-03	DELETE SMALL COOLING FAN (IN CONJUNCTION WITH ECN 1927)	1925
A	JC	22-1-03	ADD WIRING FOR REAR FAN UNIT	1927

 MONO EQUIPMENT QUEENSWAY SWANSEA WEST IND PARK SWANSEA, 396 4RD TEL: (01792) 561034 FAX: (01792) 561016	TITLE: P.C.B. OUTPUTS 4 TRAY CLASSIC ONE WAY FAN ROTATING OVEN WITH STANDARD FAN IMPELLER
ELECTRICAL SPECIFICATIONS:- 230V 1PH 50Hz	DRAWN: MT/JC
ELECTRICALLY APPROVED BY: P. BOTTLES	
DATE: 12-7-99	
DRAWING NO: M158E25-51400	
REV:	

COPYRIGHT © 1998 -- THIS DESIGN/DRAWING IS THE PROPERTY OF MONO EQUIPMENT LTD. AND MUST NOT BE REPRODUCED, COPIED, NOR ITS CONTENTS DIVULGED WITHOUT PRIOR WRITTEN PERMISSION.

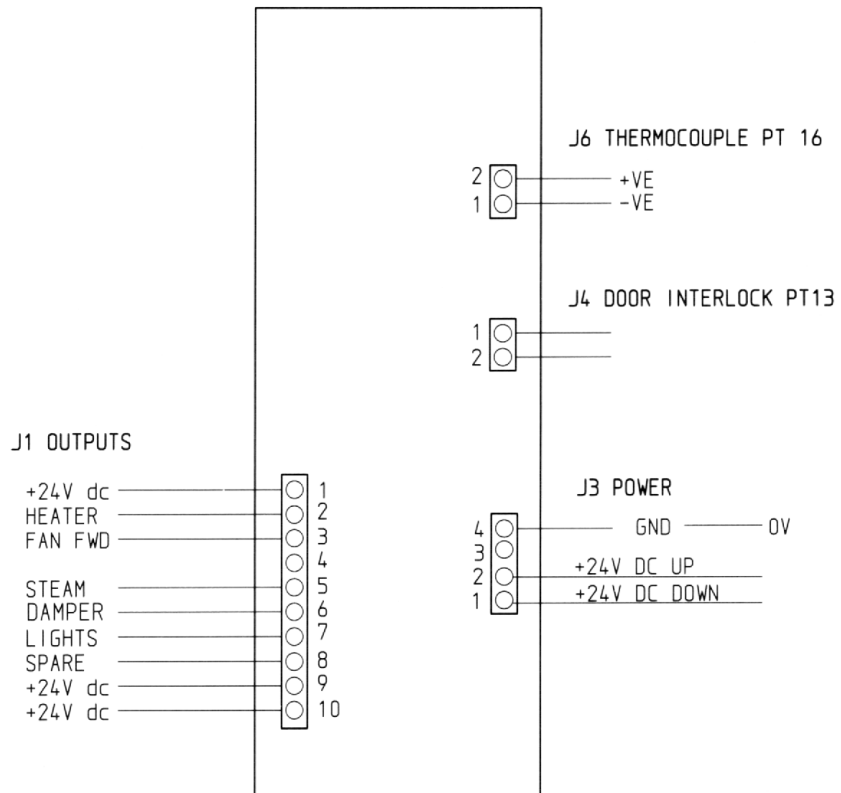
CONTROLLER BOARD AS VIEWED FROM COMPONENT SIDE
 MONO 'CLASSIC' OVEN CONTROLLER



C	JC	24-1-03	DELETE SMALL COOLING FAN (IN CONJUNCTION WITH ECN 1927)	1925
B	JC	22-1-03	ADD WIRING FOR REAR FAN UNIT	1927
A	JC	22-2-01	RE-ARRANGE POWER CIRCUIT WIRES TO PCB	14/19
REV	SIG	DATE	REVISION	ECN NO.
 MONO EQUIPMENT QUEENSWAY SWANSEA WEST IND PARK SWANSEA. SA5 4EB. TEL: (01792) 561234 FAX: (01792) 561016			TITLE: MAIN P.C.B. CONNECTIONS 4 TRAY CLASSIC ONE WAY FAN ROTATION OVEN WITH STANDARD FAN IMPELLER	
ELECTRICAL SPECIFICATIONS:-			DRAWN: MT/JC DATE: 12-7-99	ELECTRICALLY APPROVED BY:- P. BOYLES DRAWING NO. M158-25-51500 REV: C

IF IN ANY DOUBT - ASK

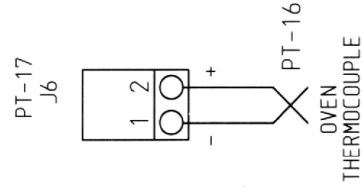
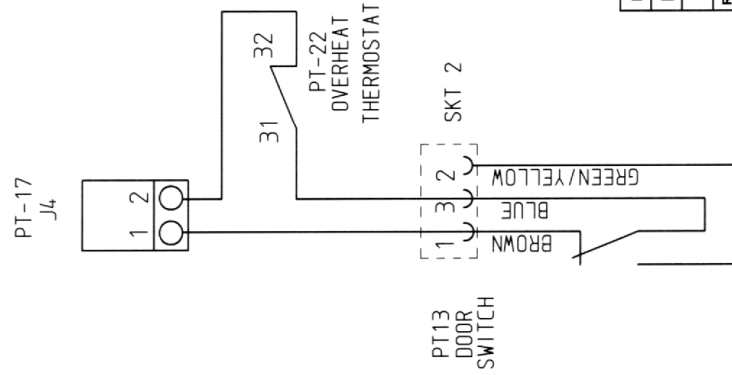
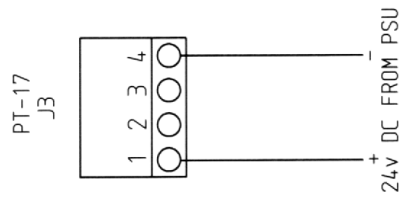

REV	SIG	DATE	DESCRIPTION	REVISION	ECON NO.
C	JC	27-03-07	PT-22 WIRED IN SERIES WITH DOOR SWITCH(PT-13)		2946
B	JC	24-1-03	DELETE SMALL COOLING FAN (IN CONJUNCTION WITH ECON 1927)		1925
A	JC	22-1-03	ADD WIRING FOR REAR FAN UNIT		1927

 MONO EQUIPMENT QUEENSWAY SWANSEA WEST IND PARK SWANSEA, SA5 4EB. TEL: (01792) 561234 FAX: (01792) 561016		TITLE: P.C.B. INPUTS 4 TRAY CLASSIC OVEN
ELECTRICAL SPECIFICATIONS:-		DRAWN: MT
ELECTRICALLY APPROVED BY:-		P. BOYLES
DATE: 26-11-98		DRAWING NO. M158E25-50500
REV: C		

COPYRIGHT © 1998 - THIS DESIGN/DRAWING IS THE PROPERTY OF MONO EQUIPMENT LTD. AND MUST NOT BE REPRODUCED, COPIED, NOR ITS CONTENTS DIVULGED WITHOUT PRIOR WRITTEN PERMISSION.

IF IN ANY DOUBT - ASK

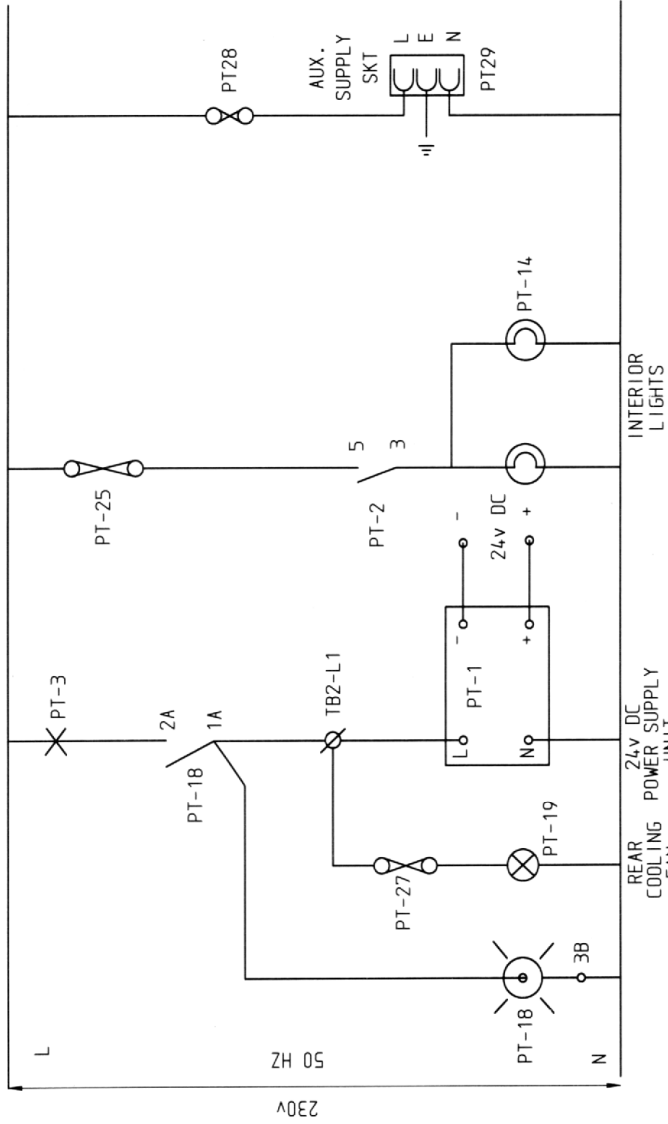

REV	SIG	DATE	REVISION	ECN NO.
D	JC	27-03-07	PT-28 & 29 ADDED	2946
C	JC	22-11-04	PT-18 CHANGED	2329
B	JC	25-9-03	SWITCH (PT-18) CHANGED	2057
A	JC	22-1-03	ADD WIRING FOR REAR FAN UNIT	1927

 MONO EQUIPMENT QUEENSWAY SWANSEA WEST IND PARK SWANSEA, GLOUCESTERSHIRE, SA4 4EB, UK TEL: (01792) 561234 FAX: (01792) 561016		TITLE: BX 4 TRAY OVEN CONTROL CIRCUIT
ELECTRICAL SPECIFICATIONS:-		DRAWN: JC ELECTRICALLY APPROVED BY: P. BOTLES
DATE: 14/12/01		DRAWING NO. M158E25-20700
REV: D		

COPYRIGHT © 1998 - THIS DESIGN/DRAWING IS THE PROPERTY OF MONO EQUIPMENT LTD. AND MUST NOT BE REPRODUCED, COPIED, NOR ITS CONTENTS DIVULGED WITHOUT PRIOR WRITTEN PERMISSION.

IF IN ANY DOUBT - ASK

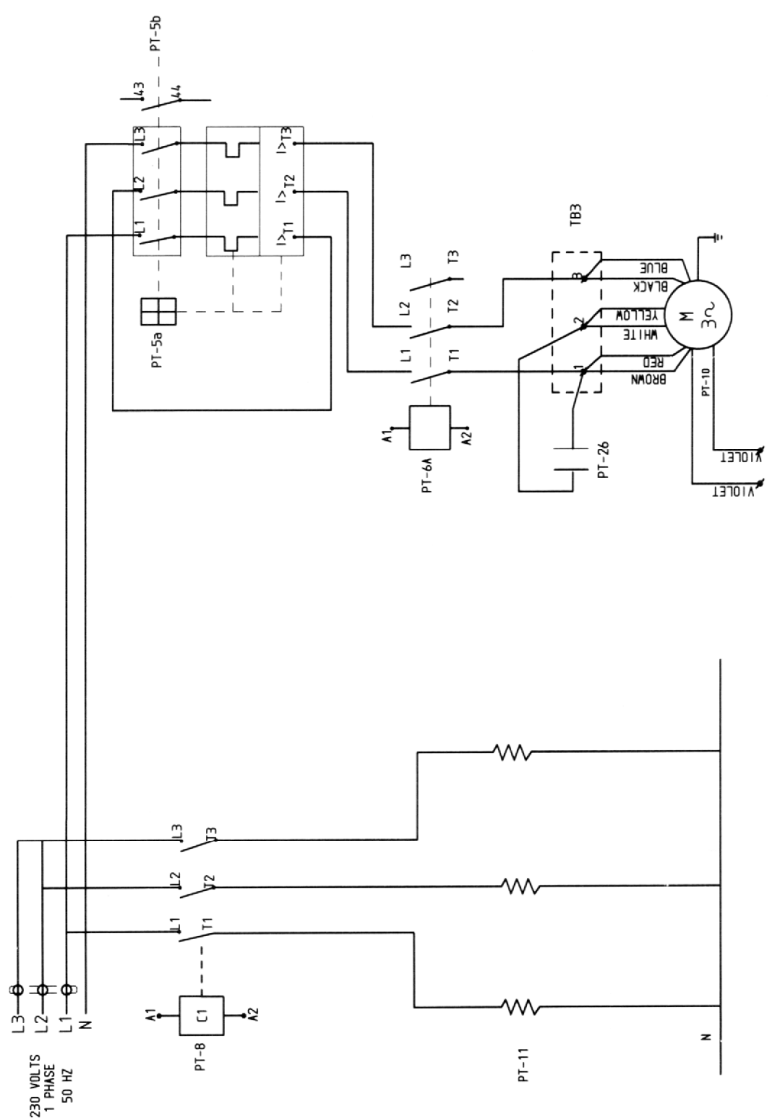

REV	SIG	DATE	REVISION	ECN NO.
A	JC	27-03-07	PT-22 REMOVED	2946
<p>MONO EQUIPMENT QUEENSWAY SWANSEA WEST IND PARK SWANSEA SA4 4EB. TEL: (01792) 561234 FAX: (01792) 561016</p>				
<p>TITLE: POWER CIRCUIT DIAGRAM 4 TRAY CLASSIC/COLOUR ONE WAY FAN ROTATING OVEN WITH STANDARD FAN IMPELLER</p>				
<p>ELECTRICAL SPECIFICATIONS:- 230V 1PH 50HZ</p>				
<p>DRAWN: JC ELECTRICALLY APPROVED BY: P. BOYLES</p>				
<p>DATE: 12-7-99 DRAWING NO. M158E25-51300</p>				
<p>REV: A</p>				

COPYRIGHT © 1998 - THIS DESIGN/DRAWING IS THE PROPERTY OF MONO EQUIPMENT LTD. AND MUST NOT BE REPRODUCED. COPIED.
 NOR ITS CONTENTS DIVULGED WITHOUT PRIOR WRITTEN PERMISSION.

IF IN ANY DOUBT - ASK

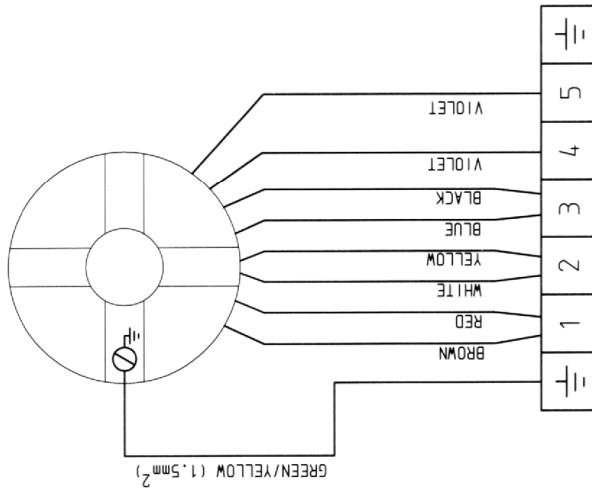

FAN MOTOR CONNECTIONS

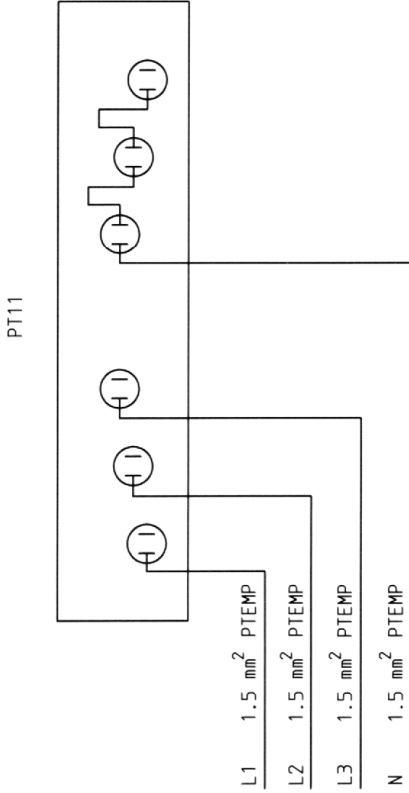

HEATING ELEMENT WIRING

REV	SIG	DATE	REVISION	ECN NO.
			FAN MOTOR CONNECTIONS & HEATING ELEMENT WIRING 4 TRAY CLASSIC/COLOUR ONE WAY FAN ROTATING OVEN	
MONO EQUIPMENT QUEENSWAY SWANSEA WEST IND PARK SWANSEA, SA 81 4E6. TEL: (01782) 861234 FAX: (01782) 861016			TITLE: DRAWN: JC DATE: 15-7-99 ELECTRICALLY APPROVED BY: P. BOYLES	
ELECTRICAL SPECIFICATIONS:-			DRAWING NO. M158E25-52200	
230V 1PH 50HZ			REV: —	

COPYRIGHT © 1998 - THIS DESIGN/DRAWING IS THE PROPERTY OF MONO EQUIPMENT LTD. AND MUST NOT BE REPRODUCED. COPIED. NOR ITS CONTENTS DIVULGED WITHOUT PRIOR WRITTEN PERMISSION.

FOR ENGINEERS USE ONLY.
DO NOT ATTEMPT ANY ALTERATIONS.
IF IN DOUBT, CONTACT MONO FOR ADVICE

CONDENSER

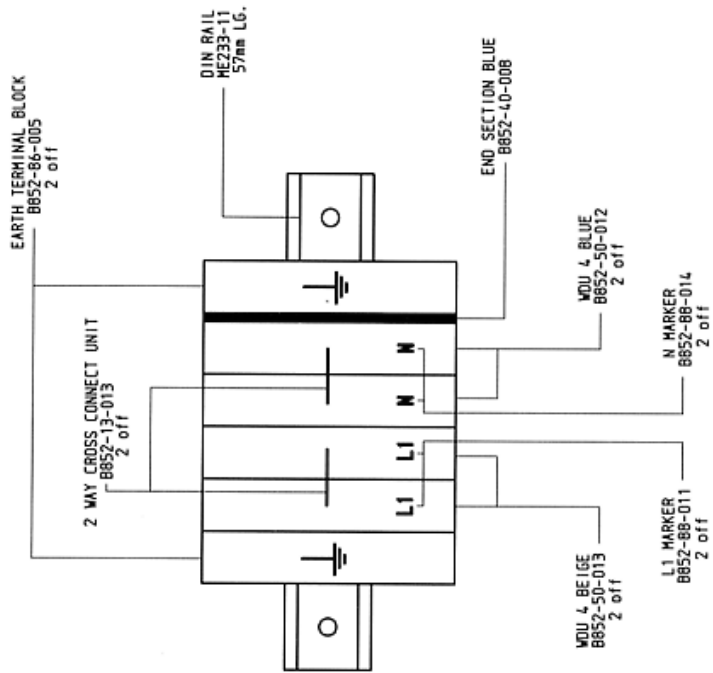

CONDENSER UNIT
 TERMINAL BLOCK LAYOUT
 M150-25-10000

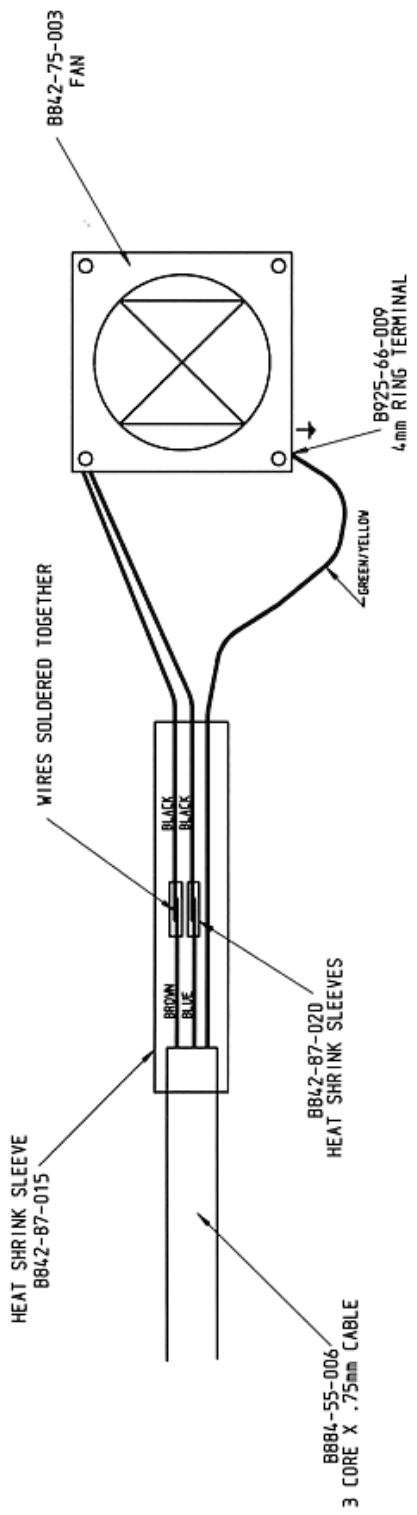

CONDENSER UNIT
 FAN CONNECTIONS
 M150-25-10200

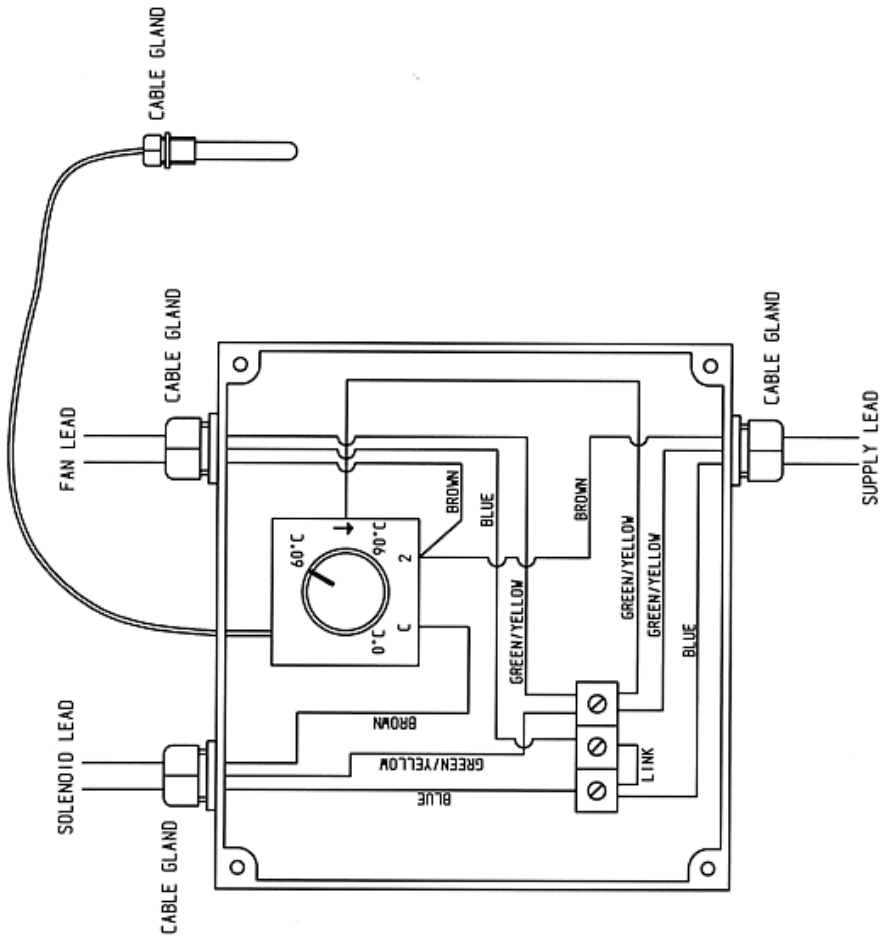

CONDENSER UNIT
ENCLOSURE BDX CONNECTIONS
M150-25-10300

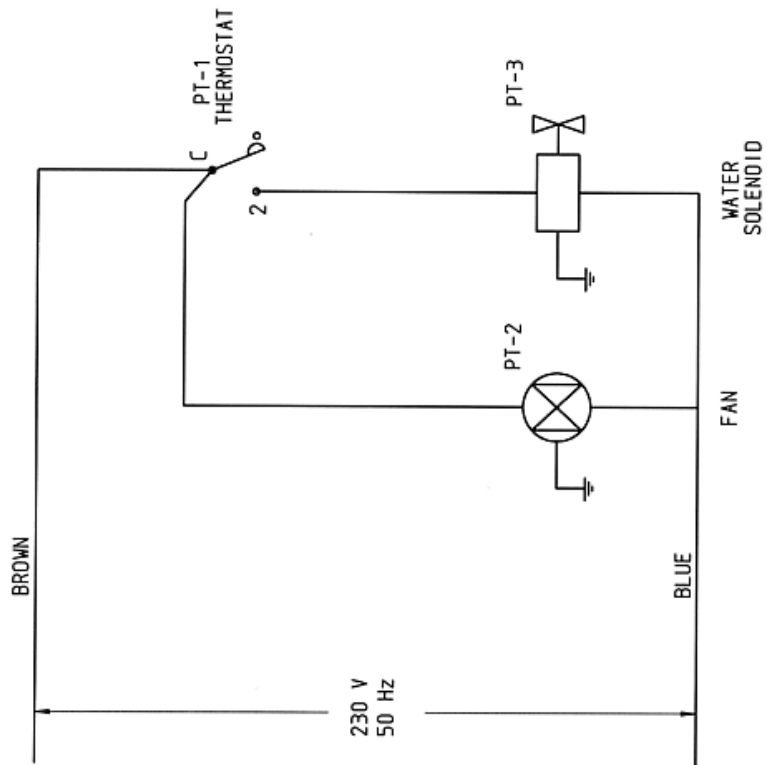

CONDENSER UNIT
CIRCUIT DIAGRAM
M150-25-10100

CONDENSER WIRING 4 TRAY OVEN

FIT LINK WIRE

L

N

E

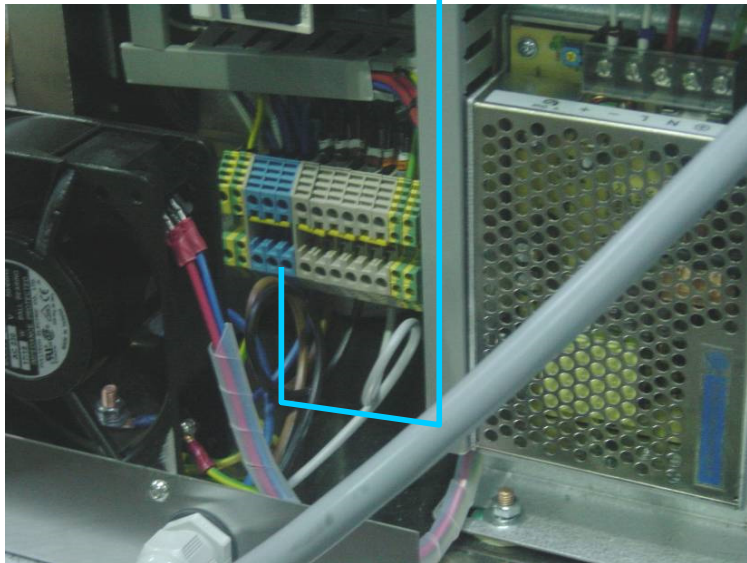
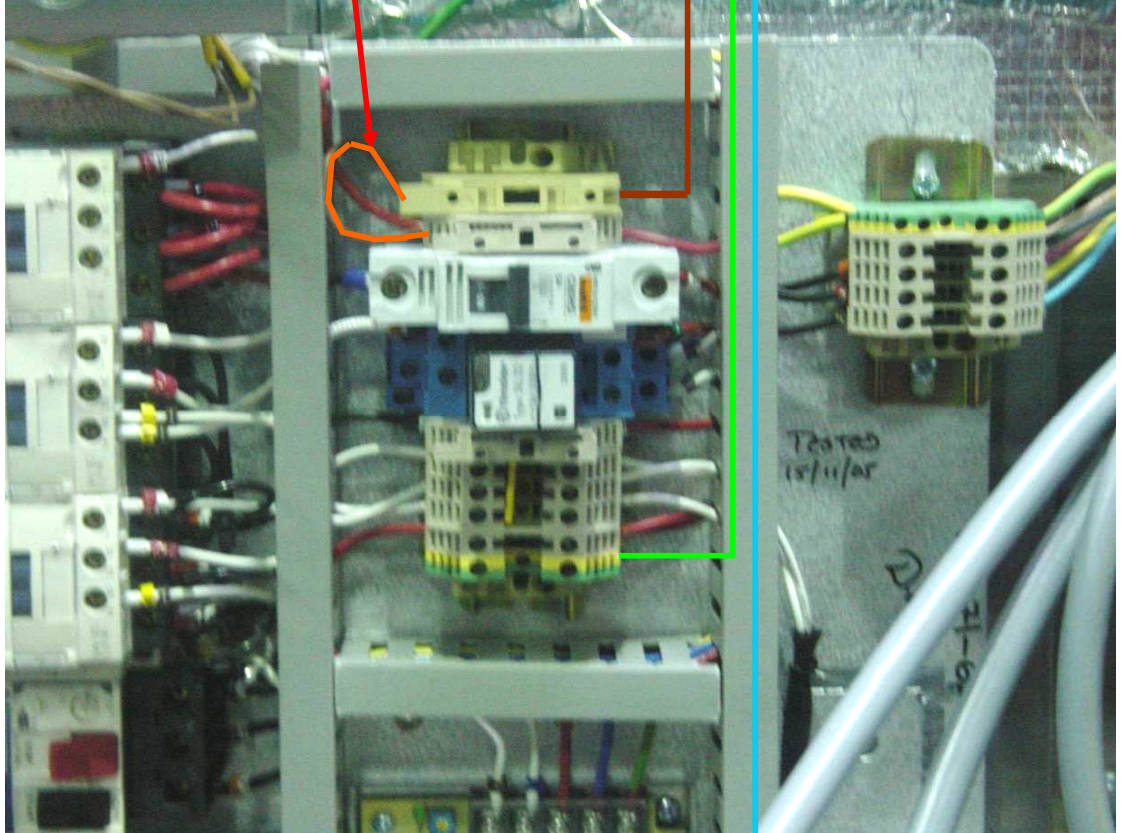

CONDENSER WIRING 10 TRAY Bx OVEN

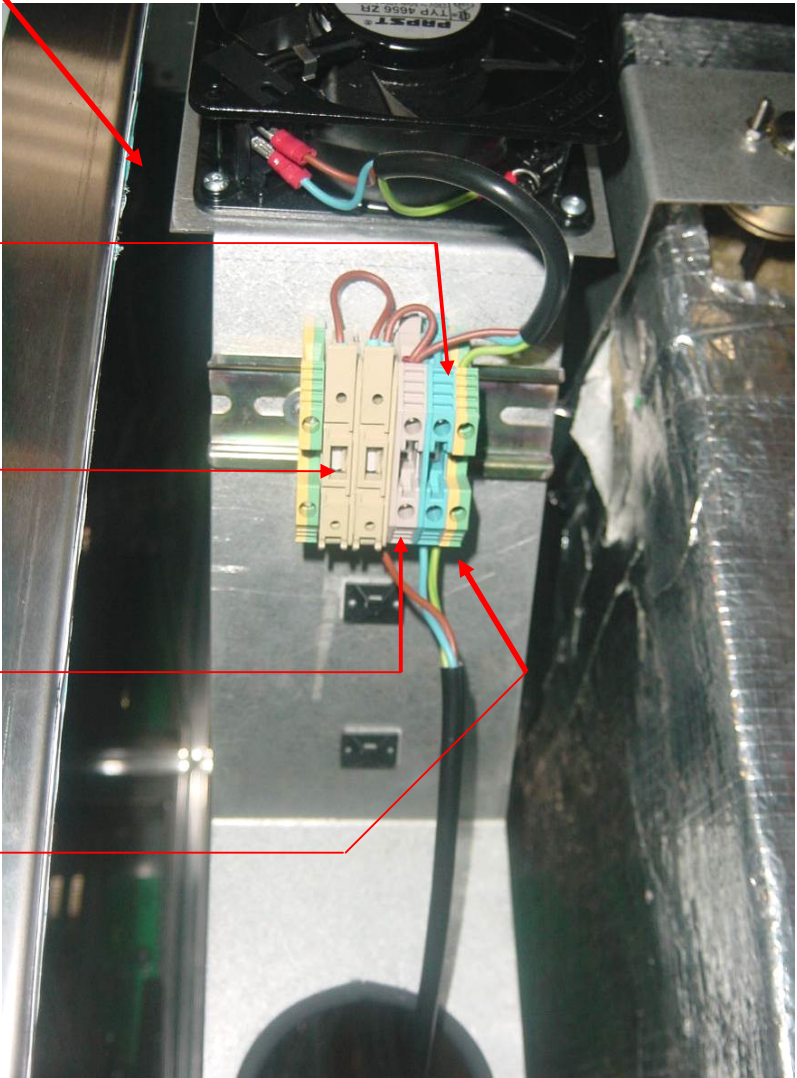
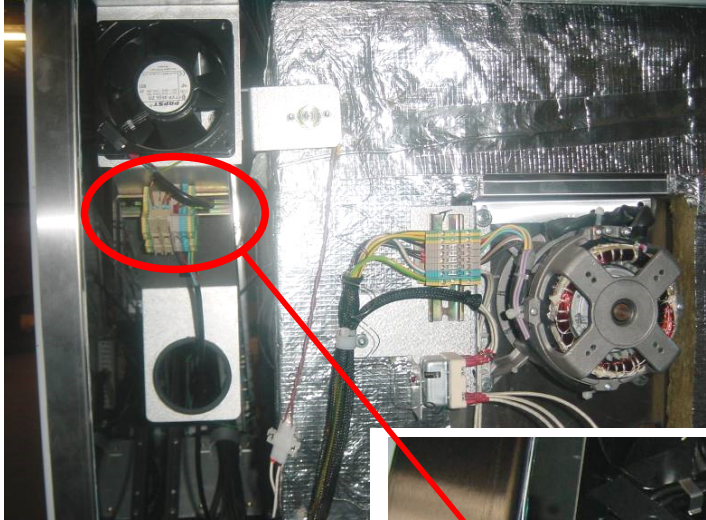

BLUE

1 AMP T FUSE

BROWN

GREEN/YELLOW

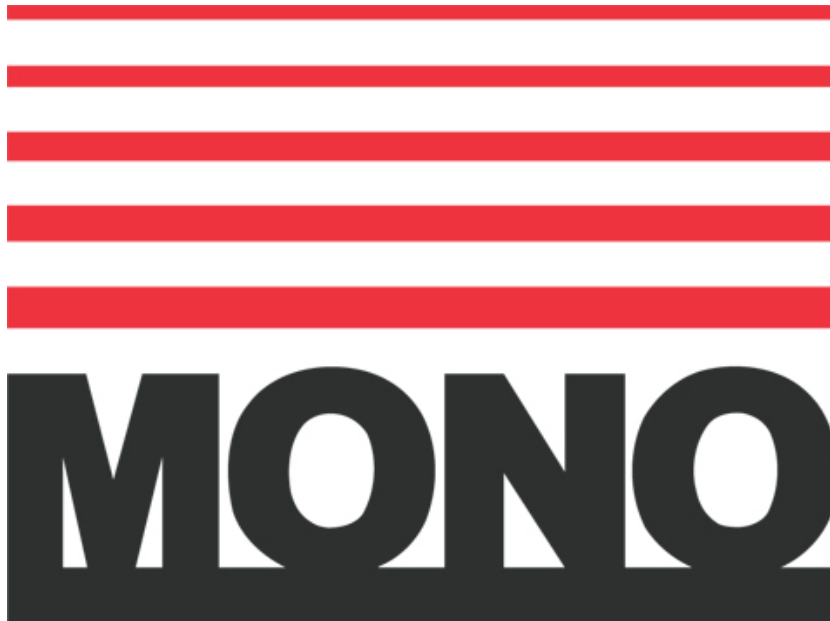

MONO Equipment

Queensway, Swansea West Industrial Park, Swansea, SA5 4EB UK

Tel. 01792 561234

Fax. 01792 561016

Email: mono@monoequip.com

www.monoequip.com

As it is our policy to improve our machines continuously, we reserve the right to change specifications without prior notice.